

Patrik Šarga, Jakub Cocuľa

DESIGN AND IMPLEMENTATION OF SMART HOME MODEL

Urgency of the research. The expansion of smart home systems is slower than was expected. One of the biggest obstacles to the mass expansion of smart homes is the high price of devices commonly available on the market. Home automation is not sufficiently widespread among people, not only for the high price, but also because the available systems do not meet users' perceptions of how they should work and also due to users' fear of security risks. For these reasons, when designing a new smart home system, it is a good idea to perform the initial testing on the model.

Target setting. Our goal was to design a model of the original low-cost smart home system, which would allow testing, tuning, and refinement of the home automation system before it is put into use. Such a model could also be used in the learning process, while students can test the proposed smart home systems on the model.

Actual scientific researches and issues analysis. When designing the model and preparing this paper, we took into account both current sources – publications and papers dealing with the current state of smart home systems as well as existing smart home solutions, which are widely available on the market.

Uninvestigated parts of general matters defining. The implementation of the proposed model into real-life operation was not realized during the research for this paper.

The research objective. The goal of the research was to model a low-cost, reliable, smart home system.

The statement of basic materials. For effective research and solution of the task of smart home system is important to create adequate model, which copies a real smart home. For our solution we used a tiny and affordable computer Raspberry Pi3, which was connected through GPIO to external sensors for light, temperature etc., operation was performed in the Python programming language and for the creation of user interface was used Cayenne platform for Android-operated smartphones.

Conclusions. Our solution implemented the Raspberry Pi microcomputer, which was connected with the external hardware. The outputs also included the creation of a physical model of the smart home system. Designed model can meet the savings, comfort and safety requirements of every household. The stability and functionality of the system designed for the model has been verified in a long-term testing. No errors in stability have been demonstrated.

Keywords: smart home; model; Raspberry Pi; Python; Cayenne.

Fig.: 6. References: 10.

The current state of smart home. A smart home can be briefly described as a residence that uses internet-connected devices to automate and monitor in-home systems. Smart home technology (often also referred as „home automation“) provides homeowners comfort, healthcare, energy efficiency and security by allowing them to control smart devices, often by a smart home app on their smartphone or other networked device [1]. Communication protocol such as RFID, NFC, ZigBee, Z-wave, Wi-Fi, Bluetooth in combination with various sensors for temperature, humidity, PIR, smoke and many others can create a mutually interconnected system (Fig. 1).

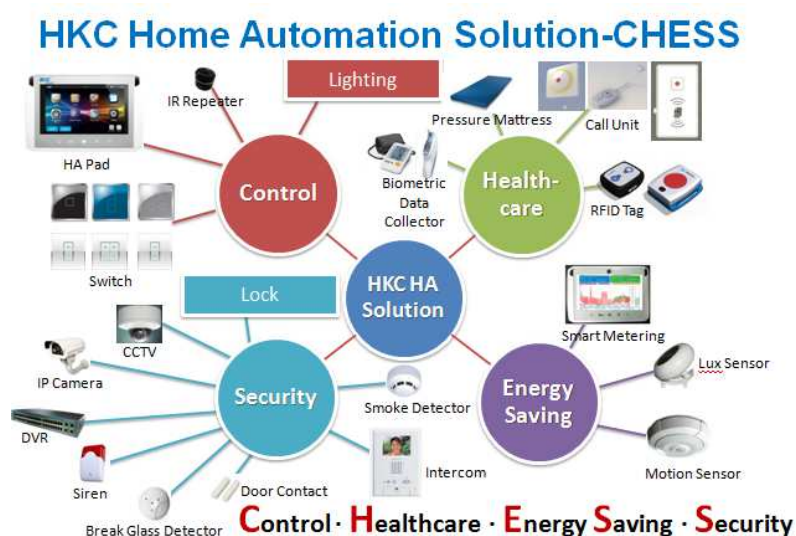

Fig. 1. Home automation solution [5]

Such a system is a combination of a sensor, a programmable device, and a transmission device that also provides a sensor output. Data from the sensor is converted into a comprehensible and processable format, then stored and compared to the predefined value. Based on this, the system will evaluate what operation to perform to meet the regulatory requirements. Information on the currently running action can be displayed to the user [2], [3], [4].

The expansion of smart home systems is slower than was expected. One of the biggest obstacles to the mass expansion of home automation is the high price of devices available on the market.

Our goal was to design a model of the original low-cost smart home system. The model would allow testing, tuning, and refinement of the home automation system before it is put into use. Such a model could also be used in the learning process, while students can test the proposed smart home systems on the model. The proposed system is based on the microcomputer Raspberry Pi, which enables the creation of a low-cost smart home.

Design of the model of the smart home system. In the current market situation, there are several options to make a smart home. The basic building element is the control unit, which is a brain of all operations. When choosing the right control unit, we draw from predefined requirements, e.g. price, programming difficulty, assembly, lifespan, connectivity, hardware variability, update, etc. Based on these criteria, we decided to implement the smart home design by using the Raspberry Pi [6], [7].

Raspberry Pi3 (further referred as “RPI”) (Fig. 2) is the third generation of RPi. It is a microcomputer based on the ARM platform. It has a small size, about a credit card size. RPi is an affordable programmable device, price level is approximately 50 €.

RPi is powered by a 3A power adapter with a minimum power consumption of 2.5W to 3.5W. It can also be connected with AAA batteries. Thanks to that it can be independent from the electrical network, although with limited battery life. RPi has four USB ports that allow sufficient connectivity for external devices. The monitor can be connected through the full-size HDMI port, so RPi can serve also as a personal computer. MIPI DSI display port enables connection of a RPi touch screen display. The image and video transmission between camera and RPi is ensured through MIPI CSI camera port. RPi also has 4-pole stereo output and composite video port. The Internet connection is via Ethernet or Wi-Fi. Additional devices can be also connected via Bluetooth. In our solution we used also 40-pins GPIO (general-purpose input/output) header. Any of the GPIO pins can be designated as an input or output pin and used for a wide range of purposes. All above-mentioned connectors were used in our solution for the model of the smart home system.

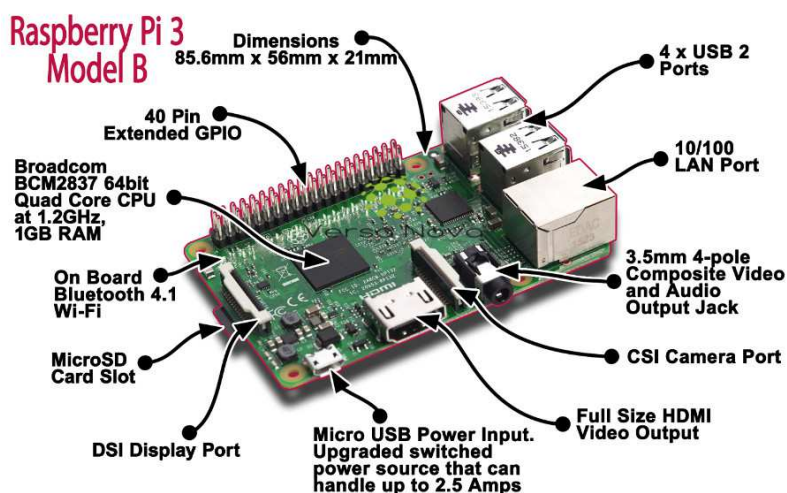

Fig. 2. Raspberry Pi3 [8]

TECHNICAL SCIENCES AND TECHNOLOGIES

The Raspberry Pi Foundation recommends the use of Raspbian, a Debian-based Linux operating system [9]. Other third-party operating systems available via the official website include Ubuntu MATE, Windows 10 IoT Core, RISC OS and specialised distributions for the Kodi media centre and classroom management. Many other operating systems can also run on the Raspberry Pi.

In our design of the model of the smart home system, we have connected GPIOs with a number of necessary sensors to control lighting, heating, shading, security, power management and entertainment. For each single smart home function, an individual connection scheme was designed and the control has been programmed in Python environment. Example of source code used for thermal regulation is shown in Fig. 3. In Fig. 4 we can see an example scheme of modeling intelligent shading.

```
import time
import RPi.GPIO as GPIO

#definovanie pinov R-cervena, G-zelena, B-modra
ledR = 14
ledG = 15
ledB = 18

#GPIO
GPIO.setmode(GPIO.BCM)
GPIO.setwarnings(False)
GPIO.setup(ledR, GPIO.OUT)
GPIO.setup(ledG, GPIO.OUT)
GPIO.setup(ledB, GPIO.OUT)

#pociatocny stav LED, vsetky svietia
GPIO.output(ledR, 1)
GPIO.output(ledG, 1)
GPIO.output(ledB, 1)
try:
    while 1:
        tempStore = open("/sys/bus/w1/devices/28-031655507fff/w1_slave")
        #ID zariadenia
        data = tempStore.read()
        tempStore.close()
        tempData = data.split("\n")[1].split(" ")[9]
        temperature = float(tempData[2:])
        temperature = temperature/1000
        print ("teplota")

        if temperature < 20: #teplota nizsia ako 20 stupnov, spustenie
            kurenie
                GPIO.output(ledR, 1)
                GPIO.output(ledG, 1)
                GPIO.output(ledB, 0)

        if temperature > 20 and temperature < 24: #zdrziavanie teploty
            medzi 20 a 24 stupnov
                GPIO.output(ledR, 1)
                GPIO.output(ledG, 0)
                GPIO.output(ledB, 1)

        if temperature > 24: #teplota nad 24 stupnov, spustenie
            klimatizacie
                GPIO.output(ledR, 0)
                GPIO.output(ledG, 1)
                GPIO.output(ledB, 1)

        time.sleep(1)
except KeyboardInterrupt:
    GPIO.cleanup()
    print ("Program ukonceny")
```

Fig. 3. Part of source code used for thermal monitoring

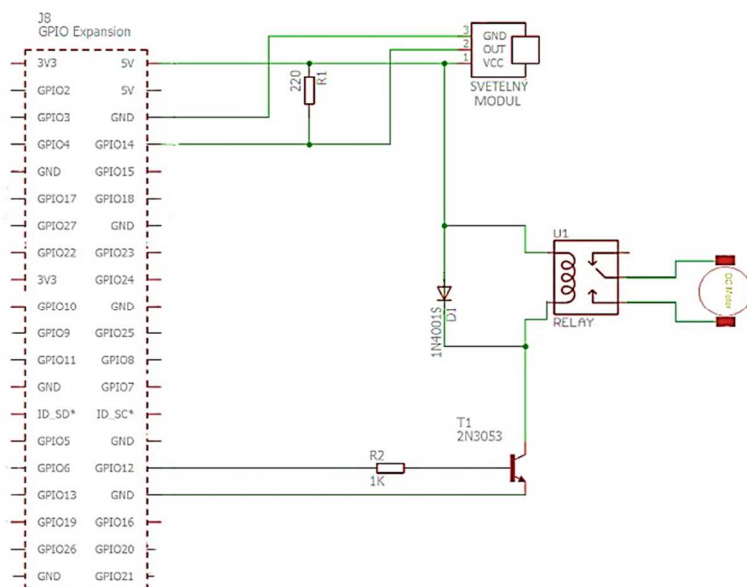

Fig. 4. Scheme of modeling intelligent shading

The user environment (Fig. 5) was created using the Cayenne platform on an Android smartphone. However, the environment is also available for iOS. The application informs the user about the individual parameters monitored and allows the user to intervene in individual processes.

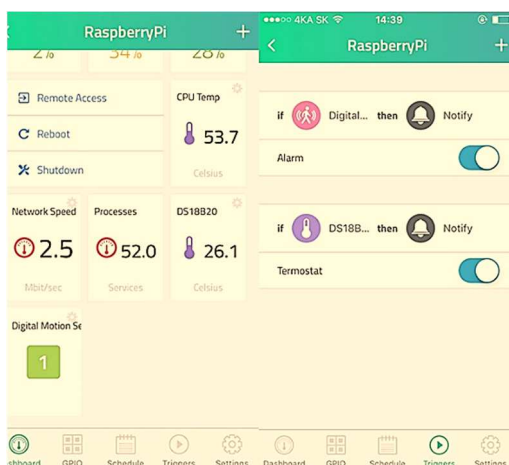

Fig. 5. The user interface

An integral part of the design process was also the creation of a physical model that contained all the suggested functions for the smart home system (Fig. 6).

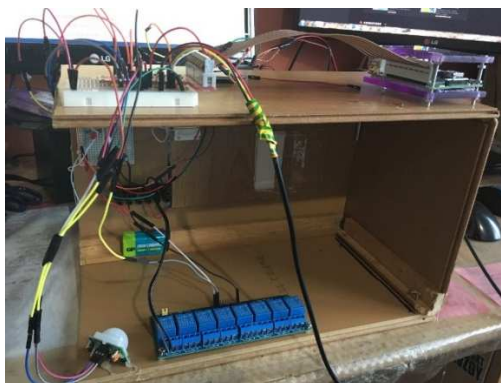

Fig. 6. The physical model of the smart home system

TECHNICAL SCIENCES AND TECHNOLOGIES

Conclusions. Our task was to design a model of cost-effective smart home system. Our solution implemented the Raspberry Pi microcomputer, which was connected with the external hardware. We have created the customized graphical user environment that is a necessity in terms of comfort of the user experience. The solution also included the creation of a physical model of the smart home system.

Our smart home model can meet the savings, comfort and safety requirements of every household. It covers a software range of commonly available features with seamless implementation to a real household. The stability and functionality of the system designed for the model has been verified in a long-term testing. No errors in stability have been demonstrated.

Acknowledgement. This work was supported by grant project KEGA 054TUKE-4/2016 Innovation of teaching courses with a focus on automation in response to the demands of industry and services and project APVV 15-0435.

References

1. Hendricks, D. (2014). The history of Smart Homes. *www.iotevolutionworld.com*. Retrieved from <http://www.iotevolutionworld.com/m2m/articles/376816-history-smart-homes.htm> [in English].
2. Smart home technology- wi-fi thermostats (2018). *www.smarthome.com*. Retrieved from <http://www.smarthome.com/wifi-thermostat.html> [in English].
3. Delaney, J. R. & Colon, A. (2017). The Best Smart Home Security Systems of 2017. *www.pcmag.com*. Retrieved from <http://www.pcmag.com/article2/0,2817,2498510,00.asp> [in English].
4. Stables, J. (2017): The best smart home systems. *www.wareable.com*. Retrieved from <https://www.wareable.com/smart-home/the-best-smart-home-systems> [in English].
5. Home automation (2018). *www.hkc.com.hk*. Retrieved from <http://www.hkc.com.hk/home-automation/> [in English].
6. King, P. (2016). *Simple electronics with GPIO zero*, Seymour Distribution. Ltd, London [in English].
7. Masarovič, R. (2014). *Softvérové vybavenie pre Raspberry Pi implementujúce funkcionality inteligentného domu*. Diplomová práca, Žilina, ŽU FRI, 91 [in Slovak].
8. Raspberry products (2018). *www.raspberrypi.org*. Retrieved from <https://www.raspberrypi.org/products/raspberry-pi-3-model-b/> [in English].
9. Goodwin, S. (2010). *Smart Home Automation with Linux*. Apress, New York, ISBN 978-1-4302-2779-3 [in English].
10. Cocuľa, Ya. (2017). *Návrh a realizácia modelu inteligentnej domácnosti*, Košice. [in Slovak].

УДК 681.31

Патрик Шарга, Якуб Кокуля

ПРОЕКТУВАННЯ ТА ВПРОВАДЖЕННЯ МОДЕЛІ РОЗУМНОГО БУДИНКУ

Актуальність теми дослідження. Впровадження систем розумного будинку відбувається повільніше, ніж очікувалося. Однією з найбільших перешкод для масового поширення розумних будинків є висока ціна на пристосування, які доступні на ринку. Будинкова автоматика недостатньо поширена серед людей не тільки через високу ціною, але й тому, що наявні системи не відповідають уявленням користувачів про те, як вони повинні працювати, а також через побоювання користувачів стосовно ризиків безпеки. З цих причин при розробці нової системи розумного будинку рекомендується виконати початкове тестування на моделі.

Постановка проблеми. Мета розробки полягала в тому, щоб спроектувати модель оригінальної недорогої системи розумного будинку, яка дозволить проводити тестування, налаштування та удосконалення системи будинкової автоматики до її введення в експлуатацію. Така модель може також використовуватися в процесі навчання, таким чином студенти зможуть тестувати пропоновані системи розумного будинку на моделі.

Аналіз останніх досліджень і публікацій. При розробці моделі та підготовці цієї статті ми враховували як поточні джерела – публікації та документи, що стосуються сучасного стану систем інтелектуальних будинків, так і наявні рішення для розумного будинку, які широко доступні на ринку.

Виділення не досліджених частин загальної проблеми. Впровадження запропонованої моделі в реальну експлуатацію не було реалізовано в процесі дослідження для цієї публікації.

Постановка завдання. Метою дослідження є моделювання недорогої, надійної системи розумного будинку.

Виклад основного матеріалу. Для ефективного дослідження й вирішення задачі системи розумного будинку важливо створити адекватну модель, яка копіює справжній розумний будинок. Для нашого рішення ми використовували крихітний і доступний комп'ютер Raspberry Pi3, який був підключений через GPIO до зовнішніх датчиків для освітлення, температури і т. ін. Робота була виконана мовою програмування Python, а для створення призначеного для користувача інтерфейсу, використовувалася платформа Cayenne для Android – керування смартфоном.

Висновки відповідно до статті. Запропоноване рішення реалізовано на мікрокомп'ютері *Raspberry Pi*, який був пов'язаний із зовнішнім обладнанням. Представлені результати також включали створення фізичної моделі системи розумного будинку. Розроблена модель може задовольняти вимогам економії, комфорту й безпеки кожного домашнього господарства. Стабільність і функціональність системи, розробленої для цієї моделі, були підтверджені при довгостроковому тестуванні. Ніяких помилок у стабільності не виявлено.

Ключові слова: розумний будинок; модель; *Raspberry Pi*; *Python*; *Scyenne*.

Рис.: 6. *Бібл.:* 10.

Patrik Šarga – Doctor of Technical Sciences, Associate Professor, Department of Automation, Control and Human Machine Interactions, Faculty of Mechanical Engineering, Technical University of Košice, Letná 9 Košice, Slovakia.

E-mail: patrik.sarga@tuke.sk

Scopus Author ID: 15128102900

Jakub Cocuľa – student of mechanical engineering, Faculty of Mechanical Engineering, Technical University of Košice, Letná 9 Košice, Slovakia.

E-mail: jakub.cocula@student.tuke.sk