

UDC 004.4

DOI: 10.25140/2411-5363-2018-4(14)-178-182

Michal Kelemen

**DESIGN OF PUCK COLLECTING ROBOT**

**Urgency of the research.** There is a need for service robots for cleaning, cutting the grass, vacuum cleaners, waste collectors etc. Service robots also can help with dangerous application like mine removing or inspection of dangerous places.

**Target setting.** Puck collecting robot is designed for collecting of wood pucks in arena and bringing to home position.

**Actual scientific researches and issues analysis.** Other similar task is collecting of products on production line in factory. Next possible application is collecting of any fruits or vegetable on plantation.

**Uninvestigated parts of general matters defining.** The questions of the design of waste collecting robots are uninvestigated, because the next research will be focused to this.

**The research objective.** Puck collecting competition is based on collecting of pucks of selected colour and bringing to home position of the same colour. Two wheeled concept of the robot with differentially driven wheels has been selected for high manoeuvrability on small place.

**The statement of basic materials.** Locomotion System structure consist of undercarriage with two geared DC motors with rubber wheels with diameter 110 mm controlled via using of locomotion microcontroller. Puck collecting system includes mechanical collector with puck color sensor, home base color sensor, puck sorter and puck handling microcontroller.

**Conclusions.** Key role of the solved robotic project is obtaining of practical experiences from the robot design and building. Robot developing is as perfect example of practical exercises. The robot is also designed as didactic tool for students training. The task of this mobile robot is similar to application in industry.

**Keywords:** Mobile robot; locomotion; sensor; color recognition; navigation.

Fig.: 7. References: 16.

**Introduction.** Currently robotic application in service area grows up. Robots are often used for cutting the grass, for vacuum cleaning etc. Design of these robots are complicated, because there is a need to integrate mechanics, electronics and software. This combination means the synergy integration [1-10].

The topic of this paper is design of mobile robot for puck collecting. It means that robot will looking for puck (rotate disc with diameter 40mm and height 20mm), collect them and bring to defined position. In practice this robot could be used for collecting of waste on streets. Other similar task is collecting of products on production line in factory. Next possible application is collecting of any fruits or vegetable on plantation. Puck collecting competition is based on collecting of pucks of selected colour and bringing to home position of the same colour. Arena is a square with 2.5m edge (fig. 1).



Fig. 1. Pucks and arena for puck collecting competition

The dimension of the robot is maximum 50 cm square with non-limited height. Time limit is 3 minute. In this time interval robot should collect own pucks and bring to home position. Colour is selected before the match. Robot cannot be aggressive against the rival robot. It looks very simple, bet robot should do several activities as:

- locomotion on arena inside the barriers,
- looking for pucks,
- recognize colour of puck,
- collect puck,
- recognize colour of ground and looking for home position of assigned colour,
- bring collected pucks to home position,
- follow the time, because time is limited,
- recognize the rival robot and avoid him.

**1. Design of the robot.** All activities have to be executed in time 3 minutes. Design of arrangement of robot undercarriage is first important step in robot design. The aim is to select the most suitable robot undercarriage (fig. 2), collecting system, sensors and control system. Two wheeled concept of the robot with differentially driven wheels has been selected for high manoeuvrability on small place. First step was design of system structure shown on figure 3.

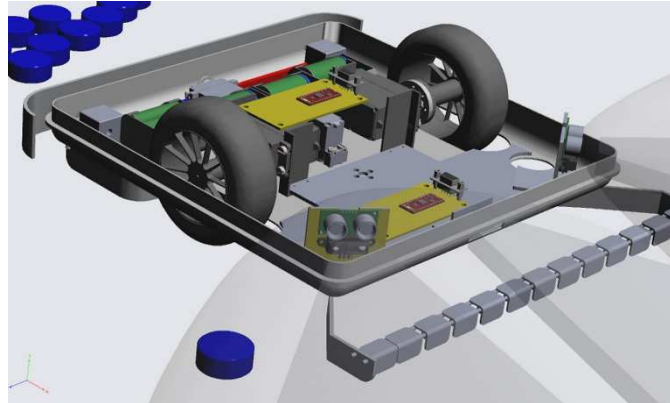

Fig. 2. Undercarriage of puck collecting robot

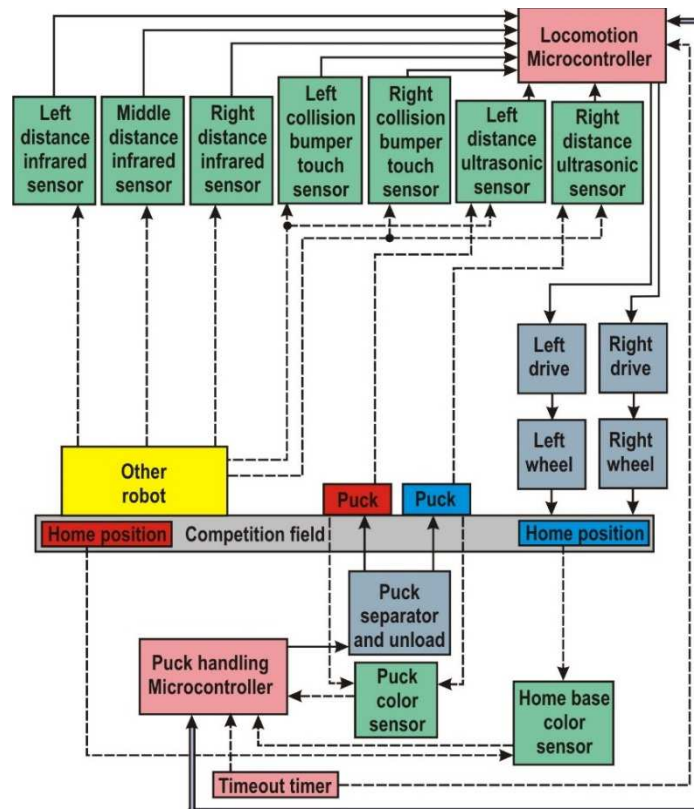

Fig. 3. System structure of puck collecting robot

System structure consist of undercarriage with two geared DC motors with rubber wheels with diameter 110 mm controlled via using of locomotion microcontroller. This microcontroller also needs collision distance sensors for sensing of pucks and rival robot. Puck collecting system includes mechanical collector with puck color sensor, home base color sensor, puck sorter and puck handling microcontroller. Both microcontroller are connected with serial interface. The system also includes real time clock timer, which gives the information about incoming end of match.

**2. Puck collector.** Puck collector consist of one way trash rack system with guider. During the robot motion, puck continues to puck color sensor and puck sorter. After sorting puck is stored in corresponding chamber (fig. 4).

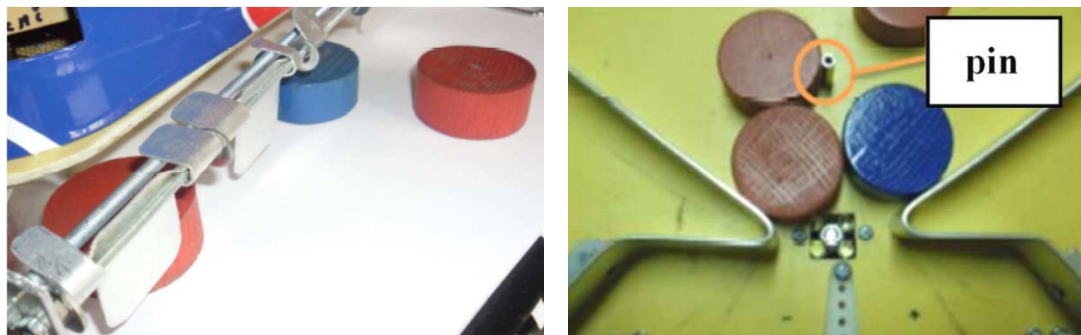

Fig. 4. Puck collector and sorting place in undercarriage of the robot

**3. Color recognition sensor.** The color sensor is necessary for recognition of puck color and home base area color. Consequently, robot needs two these color sensors. There are two color pucks and home base area color. One is red color (RAL3024) and second is blue (RAL5013). Color sensor has been made from photosensitive resistor and high intensity light LED diodes (fig. 5). Light from LED diodes is reflected into photosensitive resistor. Output of the sensor is processed with electronic part and it is captured into microcontroller.

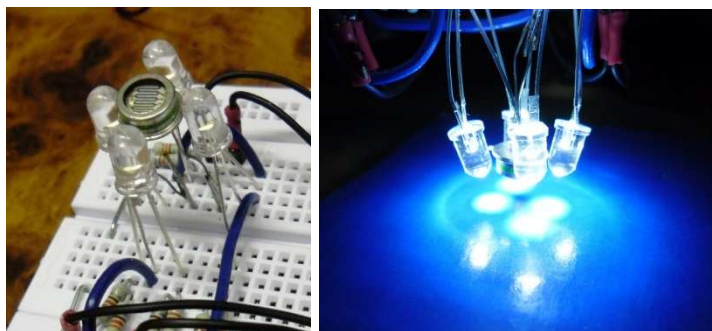

Fig. 5. Color sensor

After calibration, there is a calibration curve for red puck and blue pucks shown on fig. 6). There is a significant difference and this system can be used for color recognition of the puck and of the home base area.

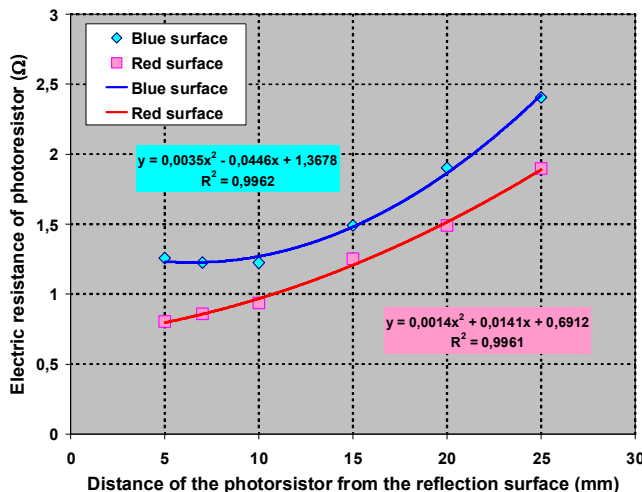

Fig. 6. Calibration curves for puck color sensing

The same sensor is used for color sensing of puck and also for the sensing of color of home base area.

**4. Collision sensors.** Collision sensor are used for detection of pucks and rival robot before our robot. For this purpose is used ultrasonic sensor and infrared sensor as wireless sensors, but also there are whiskers as touch sensors.

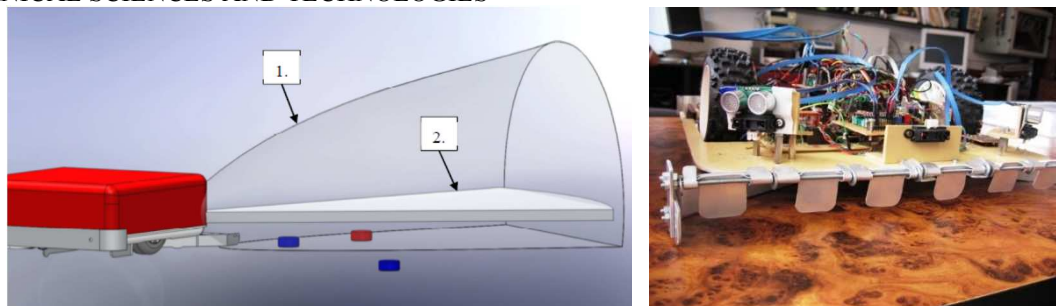

Fig. 7. Collision and navigation sensors

**5. Final robot realization.** Finalized robot has attend of the competition. The robot was looking for pucks and made obstacle avoidance. Robot is fully autonomous without any remote controlling. Robot is moved by the geared DC motors. DC motors are equipped with encoder position system as feedback information for the control system.



Fig. 7 Finalized robot and attendance on competition

**Conclusion.** Key role of the solved robotic project is obtaining of practical experiences from the robot design and building. Robot developing is as perfect example of practical exercises. The robot is also designed as didactic tool for students training. The task of this mobile robot is similar to application in industry [11-16].

**Acknowledgement.** The authors would like to thank to Slovak Grant Agency – project KEGA 018TUKE-4/2018, and FGV/2016 supported by Faculty of Mech. Eng. at Technical University of Kosice.

### References

1. JUANG L. H., WU, M.N., WENG, Z. Z. (2014) Object identification using mobile devices, *Measurement*, Volume 51, May 2014, Pages 100-111.
2. LIU, Z., LI, F., ZHANG, G. (2014) An external parameter calibration method for multiple cameras based on laser rangefinder, *Measurement*, Volume 47, January 2014, Pages 954-962.
3. NAGATA, F., KITAHARA, N., OTSUKA, A., SAKAKIBARA, K., WATANABE, K., HABIB, M.K., A proposal of experimental education system of mechatronics, *Artificial Life and Robotics*, Volume 17, Issue 3-4, 2013, Pages 378-382.
4. BENAVIDEZ, P., GLEINSER, C., JAIMES, A., LABRADO, J., RIOJAS, C., JAMSHIDI, M., ENDOWED, L.B. (2012) *Design of semi-autonomous robots for competitive robotics*, World Automation Congress Proceedings, World Automation Congress, WAC 2012; Puerto Vallarta; Mexico; 24 June 2012 through 28 June 2012; Code 94214, (2012).
5. HUNG GUO J. et al. (2013) Motion Planning of Multiple Pattern Formation for Mobile Robots, *Applied Mechanics and Materials*, Volumes 284 - 287, January, 2013, pages 1877-1882.
6. BABINEC, A., DEKAN, M., DUCHON, F., et al. (2012). Modifications of VFH navigation methods for mobile robots. *Procedia Engineering*. 48 (2012), pp. 10-14. DOI: 10.1016/j.proeng.2012.09.478.
7. SIMONOVA, A., HARGAS, L., KONIAR, D. (2017). Uses of on-off controller for regulation of higher-order system in comparator mode. *Electrical Engineering*. 99 (4), pp. 1367-1375. DOI: 10.1007/s00202-017-0610-7.



8. DUCHON, F., HUNADY, D., DEKAN, M. et al. (2012). Optimal navigation for mobile robot in known environment. 11th International Conference on Industrial, Service and Humanoid Robotics (ROBTEP 2012) Location: Strbske Pleso, Slovakia. pp. 33. DOI: 10.4028/www.scientific.net/AMM.1000.33.
9. KONIAR, D., HARGAS, L., LONCOVA, Z., ET AL. (2017). Visual System-Based Object Tracking Using Image Segmentation For Biomedical Applications. *Electrical Engineering*. 99 (4), PP. 1349-1366. DOI: 10.1007/S00202-017-0609-0.
10. GMITERKO, A., KELEMEN, M., KELEMENOVÁ, T., MIKOVÁ, L. (2010). Adaptable Mechatronic Locomotion System. *Acta Mechanica Slovaca*. 14 (2). pp. 102-108.
11. KONIAR, D., HARGAS, L., SIMONOVA, A. et al. (2014). *Virtual Instrumentation for Visual Inspection in Mechatronic Applications*. 6th Conference on Modelling of Mechanical and Mechatronic Systems (MMaMS) Location: Vysoke Tatry, SLOVAKIA Date: NOV 25-27, 227-234.
12. DUCHOŇ, F., HUBINSKÝ, P., HANZEL, J., BABINEC, A., & TÖLGYESSY, M. (2012). Intelligent Vehicles as the Robotic Applications. *Procedia Engineering*, 48 (2012), 105–114. doi.org/10.1016/j.proeng.2012.09.492.
13. KONIAR, D., HARGAS, L., & ŠTOFAN, S. (2012). Segmentation of Motion Regions for Biomechanical Systems. *Procedia Engineering*, 48 (2012). 304–311. DOI: doi.org/10.1016/j.proeng.2012.09.518.
14. TURYGIN, Y., & BOŽEK, P. (2013). Mechatronic systems maintenance and repair management system. *Transfer of innovations*, 26 (2013). 3-5.
15. SPANIKOVA, G., SPANIK, P., FRIVALDSKY, M. et al. (2017). Electric model of liver tissue for investigation of electrosurgical impacts. *Electrical Engineering*, 99 (4). 1185-1194. doi.org/10.1007/s00202-017-0625-0
16. KARAVAEV, Y. L., & KILIN, A. A. (2016). *Nonholonomic dynamics and control of a spherical robot with an internal omniwheel platform: Theory and experiments*. Proceedings of the Steklov Institute of Mathematics, 295 (1), 1 November 2016, 158-167.

УДК 004.4

Міхал Келемен

## ПРОЕКТУВАННЯ РОБОТА ДЛЯ ЗБИРАННЯ ШАЙБ

**Актуальність теми дослідження.** Існує потреба в сервісних роботах для прибирання, покосу трави, пилюсів, складання сміття і т.д. Сервісні роботи також можуть допомогти з небезпечними видами робіт, таким як прибирання у шахтах або огляд небезпечних місць.

**Постановка проблеми.** Робот для збирання шайб призначений для збирання дерев'яних шайб на ділянці й повернення їх у початкове положення.

**Аналіз останніх досліджень і публікацій.** Іншим аналогічним завданням є транспортування готової продукції виробничої лінії на заводі. Наступне можливе застосування – збір будь-яких фруктів або овочів на плантації.

**Виділення недосліджених частин загальної проблеми.** Питання розробки роботів, що збирають відходи, не досліджені, тому наступне дослідження буде зосереджено на цьому.

**Постановка завдання.** Конкурс зі збирання шайб заснований на збиранні шайб обраного кольору і транспортування їх у вихідне положення. Для високої маневреності в обмеженому просторі, була обрана двоколісна концепція робота з незалежним приводом коліс.

**Виклад основного матеріалу.** Конструкція системи переміщення складається з шасі з двома редукторними двигунами постійного струму з гумовими колесами діаметром 110 мм, керованими за допомогою мікроконтролера переміщення. Система збирання шайб включає механічний колектор з датчиком кольору шайби, датчик основного кольору, сортувальник шайб і мікроконтролер обробки шайб.

**Висновки відповідно до статті.** Основна мета запропонованого робототехнічного проекту – отримання практичного досвіду проектування і виготовлення робота. Розвиток роботів - прекрасний приклад практичних вправ. Робот також розроблений як дидактичний інструмент для навчання студентів. Можливості запропонованого мобільного робота відповідають завданням, які вирішуються в промисловості.

**Ключові слова:** мобільний робот; переміщення; сенсор; розпізнавання кольорів; навігація.

Рис.: 7. Бібл.: 16.

**Kelemen Michal** – Prof. Ing., PhD., Faculty of Mechanical Engineering, Technical University of Kosice (Letna 9, 04200 Kosice, Slovakia).

**E-mail:** michal.kelemen@tuke.sk

**Researcher ID:** J-2845-2013

**Scopus Author ID:** 8396804800