

Marin Višňovský, Róbert Rákay, Alena Galajdová, Dušan Šimšík

PROPOSAL OF THE MODULE FOR EXPERIMENTAL WORKPLACE BASED ON PLATFORM INDUSTRY 4.0

Urgency of the research. New modern trends in the cable industrial communication and exchange of data focus on implementation of new communication standards, protocols and reduced costs. Communication in every automation systems is crucial. Functions of these systems is very important for the correct function of automation system.

Target setting. For designing sensor and actuator systems for automation and solving connection between different devices, developers solved this problem with standardized communication like technology IO-Link. This communication technology together with industrial bus create solution for modern communication with quantity of benefits like quick design and diagnostic, unified interface, cost and work reduction.

Actual scientific researches and issues analysis. To prepare this paper, we analyzed different solutions for communication between sensors and actuators, different control systems and mechanical solutions. We used knowledge from our previous experiments and choose optimal components and systems for our project.

Uninvestigated parts of general matters defining. There are many different types of sensors, actuators, communication interfaces and industrial busses. This paper is insufficient to describe them all. That's why we've only described those, which will be used.

The research objective. This article describe the design of a machining module for the FESTO FMS 500 Modular Laboratory System. This module will be physically implemented as part of the revitalization and modernization of the FMS 500 laboratory system at the Department of Automation, Control and Human-Machine Interactions.

The statement of basic materials. We follow the trends in industrial automation and the requirements of the 4th Industrial Revolution. This is reason why we use IO-Link technology in combination with Profinet bus for communication with sensors and actuators.

Conclusions. The main objective of this article is to approach the design of the Machining Module with Industry 4.0 elements for the Modular Production System FMS 500. This design describe the individual components which will be used. The functions and purpose of the module are also describe, as well as its functional capabilities in terms of diagnostics.

Keywords: automation; control; PLC; IO-Link; Cloud; wireless communication; pneumatic systems; Industry 4.0.

Fig.: 8. References: 15.

Introduction. The development of modern technologies in automation raises increased demands for well prepared engineers. The modernization of lines with a higher degree of automation, robotics and mobile diagnostic and control technologies follows the objectives of Industry 4.0. Tracking and responding to these trends are therefore very important in the field of research and teaching. Our response to these trends is the upgrading of the FMS 500 Modular Laboratory System from FESTO to the Industry Platform 4.0, which will also include a new workspace module [1].

This module will be physically implemented from construction, through selection and assembly of drives and steering members to recovery. Design and selection of used components fit into complex revitalization of the entire system and ensure compatibility of individual modules. In the framework of this modernization, the replacement of SIEMENS Simatic S7-300 controllers (PLCs) behind PLC Simatic S7-1500 will be realized. Change industry bus from Profibus to Profinet will be realized too. Sensors modification and implementation of IO-Link technology for sensor communication, application of wireless industrial communications, and storage of process data to Cloud. By using these technologies, we will achieve a line structure so we can validate modern approaches and tasks in industrial automation [2; 3].

Construction design. The design of the module is based on the concept of individual modules of the modular system FMS 500 (Fig. 1).



Fig. 1. Complete configuration of FMS500 [4]

The base of the module is made of T-shaped aluminum profiles. On this base plate will be placed a manipulator, consisting of a rodless pneumatic drive, which is fastened on the aluminum profile to the desired height above the base plate. A double-acting actuator with one-sided piston rod is mounted on the slide table of this drive. At the end of the piston rod, the pneumatic actuator is attached to grab the parts to be handled.

On the base plate will be a 4-position rotary table, which will be rotated by a stepper motor. Individual devices will be placed in each position to perform individual operations. These devices will also be attached to aluminum profiles. The preliminary basic design is in Fig. 2.

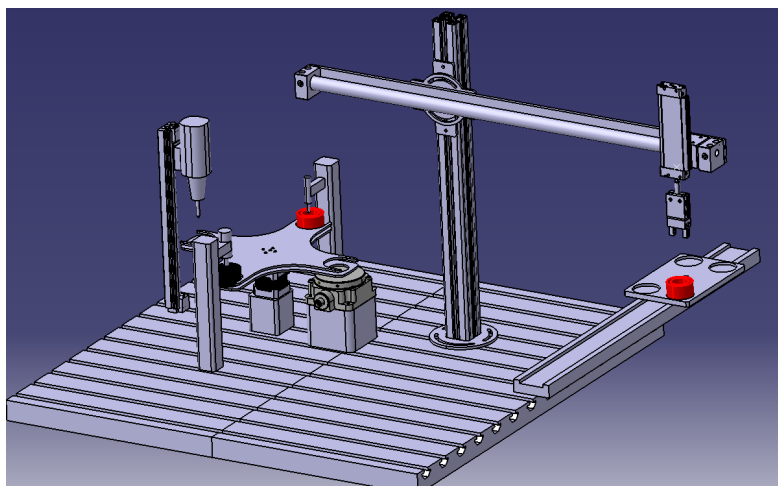

Fig. 2. Construction design of machining module

Design and selection of components. The design solution could be divided into three parts. The first part is the handling part, the second part are the processes on the turntable (machining part). The third part is the control part (control components).

Handling part. This part consists only of pneumatic components. All pneumatic drives used in this module are from SMC. For motion in the X axis, a rodless pneumatic drive with mechanical connection to the slide table, MY1B10G-500H will be used. This drive has a piston diameter of 10mm and a stroke of 500mm. At both ends there are hydraulic silencers with adjusting screw. (Fig. 3) Achieving the end positions will be detected using PNP sensors in the grooves of this drive.



Fig. 3. SMC MY1B10G-500H

For Y-axis movement, a double-acting pneumatic drive with a one-sided rod will be used. Type of drive is CD85KN12-100-B. This drive has a piston diameter of 12mm and a stroke of 100mm. Piston anti-rotation insurance is realized in such a way that the piston has no circular but hexagonal cross-section. (Fig. 4) Reaching the end positions will be detected by using PNP sensors mounted on the surface of the cylinder by metal strips.



Fig. 4. SMC CD85KN12-100-B

TECHNICAL SCIENCES AND TECHNOLOGIES

The pneumatic parallel actuator with two fingers, type MHZ2-10D will be used to attach the component. This drive has a piston diameter of 10mm. On the fingers of this effector, the extensions are screwed exactly according to the size and shape of the part to be handled. These extensions were made with 3D printing from material PLA (Fig. 5) Reaching the end positions will be detected using PNP sensors in the grooves of this drive.

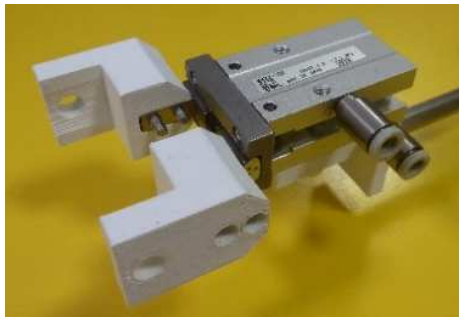

Fig. 5. SMC MHZ2-10D

The individual components are joined together and their position can be adjusted using plastic plates modeled for this application and also produced by 3D printing from the same material as the finger of the effector (Fig. 6).



Fig. 6. Adjustment plastic plate

Machining part. The base of the machining part will be a rotary table made of plexiglass. There are 4 positions for the placement of parts on this table. There will be a different operation for each position. This rotary table will be mechanically coupled to the shaft of the two-phase stepper motor controlled by the stepper motor driver (Fig. 7).

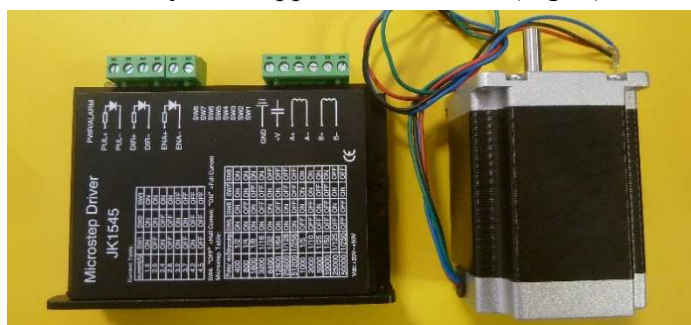

Fig. 7. Two-phase stepper motor with stepper motor driver

On the first post of machining part, will be a read/write RFID head with IO-Link communication from Balluff. It is the head - BIS M-401-045-001-07-S4 (Fig. 8).



Fig. 8. RFID read/write head

On the second post there will be a workplace for checking the height of the component before drilling. A single-acting actuator with a one-sided rod, type CD85N8-50S-B, will be used for this control. This drive has a piston diameter of 8mm and a stroke of 50mm. Reaching the end positions will be detected by using PNP sensors mounted on the surface of the cylinder by metal strips (Fig. 9).



Fig. 9. SMC CD85N8-50S-B

The third position is the workplace with a drill. The drilling head (chuck) with a drill bit will be placed on a base that will be attached to slide table of rodless pneumatic actuator MY1B10G-200H. This drive has a piston diameter of 10mm and a stroke of 200mm. At both ends there are hydraulic silencers with adjusting screw. (Fig. 10) Reaching the end positions will be detected by using PNP sensors in the grooves of this drive.



Fig. 10. SMC MY1B10G-200H

During drilling operation, the component will hold in the correct position on the turntable by the single-acting actuator with the single-sided rod, type CD85N8-25S-B. This drive has a piston diameter of 8mm and a stroke of 25mm. Reaching the end positions will be detected by using PNP sensors mounted on the surface of the cylinder by metal strips. (Fig. 11)



Fig. 11. SMC CD85N8-25S-B

The last position will be a workplace with a blowing nozzle that will simulate the removal of chips after the drilling process. On all pneumatic actuators except effector, will be fittings with a one-way throttle valve. On double-acting with throttling at the outlet and on single-acting with inlet throttling. These valves will be allowed setting the speed of each drive.

TECHNICAL SCIENCES AND TECHNOLOGIES

Control part. The base of control part be the PLC SIEMENS Simatic S7-1500 CPU 1512C-1PN (Fig. 12). This PLC has a compact CPU with one network card for Profinet with a two-port switch. It has 5 analog inputs, 2 analog outputs, 32 digital inputs and 32 digital outputs. There is also a small color control panel and 6 control buttons in the base rack of this PLC. Below this panel there is an SD card slot and a PLC mode switch.



Fig. 12. PLC SIEMENS Simatic S7-1500 CPU 1512C-1PN

The PLC will be powered by one of the two SIEMENS Simatic PM 1507 sources (Fig. 13). These are sources with 24V/8A/190W output. These sources are size and shape-matched to the PLC Series S7-1500. A pair of resources is used for the application of IO-Link technology, which allows separate feeding of the control technology with sensors and actuators. The reason is that if one of the action members fails, or overload and source protection shuts down this source, the control member and sensors can work further. The operator receives information about the fault location.



Fig. 13. Sources SIEMENS Simatic PM 1507

The main device for IO-Link application will be the IO-Link master from BALLUFF - BNI PNT-538-105-Z063 (Fig. 14). It is an 8-port IO-Link master with Profinet communication. All ports of this master can be used with IO-Link communication. 4 ports of this master is type A and 4 ports is type B. Ports type be allow redundant (galvanic isolated) sources, one for actuators and one for control unit and sensors. The following devices will be connected to individual IO-Link ports: RFID reader and writer head, valve island, and HUB expander for digital inputs and outputs. 5 free ports can be used like IO-Link or like standard I/O. Into each port we can connect two digital signals (input or output).



Fig. 14. BALLUFF - BNI PNT-538-105-Z063

The IO-Link device BNI IOL-302-S01-Z013 (Fig 15) will be used to connect multiple digital inputs (sensors from drives). It is an expanding 8-port HUB also from BALLUFF. We can connect up to 16 sensors (digital inputs) to these 8 ports.



Fig. 15. BALLUFF – BNI IOL-302-S01-Z013

The last control device is a valve island with IO-Link communication from SMC (Fig. 16). The communication module has the designation EX260-SIL1-X210. This island has been configured to meet the requirements of this application. The valve consists of two bistable 5/2 valves for control of rodless drives, two monostable 5/2 valves for controlling a double acting actuator and an effector, and finally two valves in which two monostable 3/2 valves (together 4x 3/2 valves) are connected. These valves will control two single acting actuators and a nozzle on the air outlet. One 3/2 valve remains free. All pneumatic drive control will be implemented with IO-Link communication with additional diagnostic functions via one 5-core cable.



Fig. 16. SMC EX260-SIL1-X210

The structure of connection and use of individual communication technologies is shown in Fig. 17. The figure shows the PLC connection to the power supply and Profinet communication bus. This bus connecting PLC, IO-Link master and PC. Through the standard digital signals, a stepper motor driver is connected to the PLC. The IO-Link master is powered by both sources. One for drives, second for sensors and control electronics. This two power supplies are also available for an expanding HUB that communicates with the master via IO-Link. Digital sensors from pneumatic drives are connected in standard way to the HUB. Via IO-Link, a valve island and an RFID head are also attached to the master. The figure does not contain all the used elements and all functional connections (only the connection structure, not the wiring diagram).

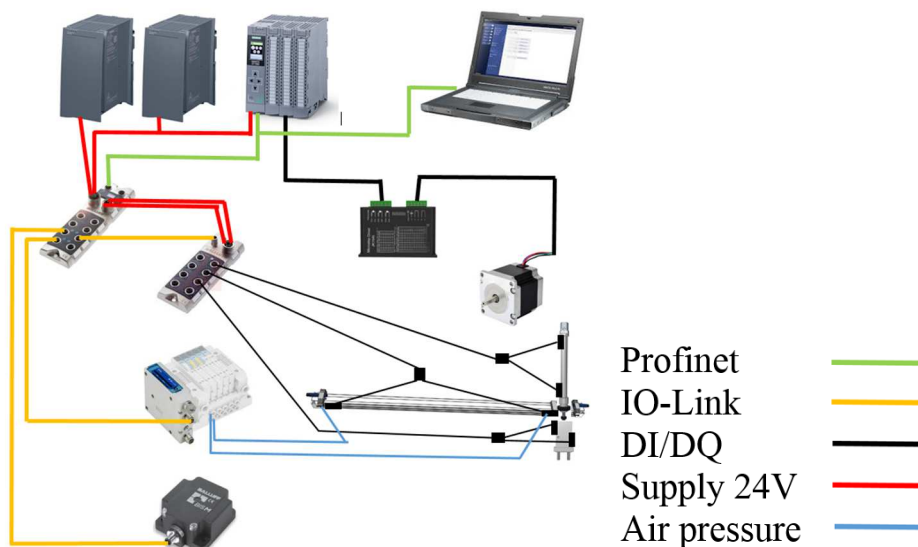

Fig. 17. Connection structure

Modul functions. The workstation module will be able to work either as a single workstation or will be able to be connected to the FMS 500 after its upgrading. The structure of the functionalities of the individual parts of the module is shown in Fig. 18.

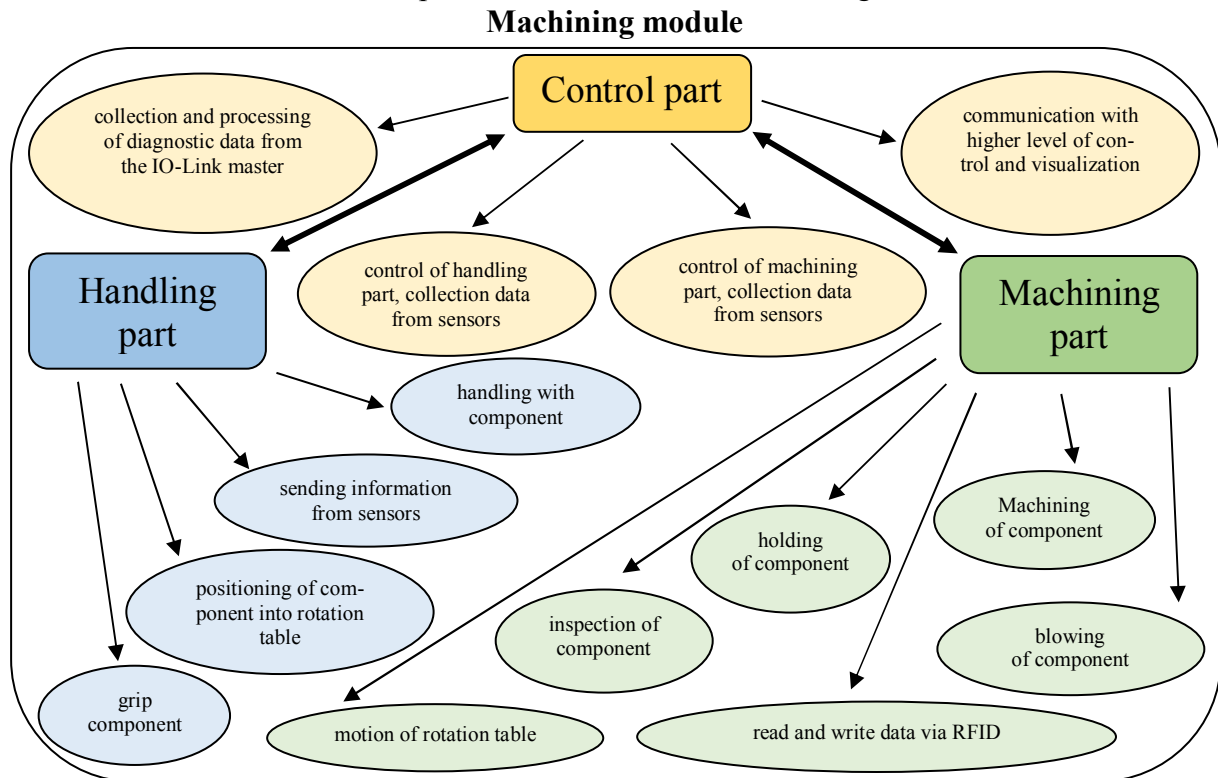

Fig. 18. Block diagram of module functions

The function of this module will be to move the components with pneumatic manipulator from belt (if module will connect to FMS 500) or from preset point (if station will be stand-alone) on the rotation table. After placing the component on the first table post, the RFID head will be loaded an RFID tag that will be placed on the individual parts. This tag will contain information about the type of component and the machining operations to be performed on this component. Based on this information, the control system evaluates which operations will be performed on that component.

After the RFID tag is loaded, the table is rotated 90 degrees and the part is moved to post number 2. The height control of the component is performed by pneumatic drive. After the height is evaluated, the operations will be continued according to the set algorithm. The part moves from position 2 to position number 3 where is drilling operation. PLC via relay, resp. the contactor is powered by an electric drive with a chuck where the drill will be placed. After the drive starts, the drill head starts and starting with move down. After the required height has been reached, the downward movement stops and the drill head returns to the initial position where the drill drive stops.

Subsequently, the component moves to the fourth post where the nozzle will realized blowing of component. After this cycle, the round table cycle closes by moving the component to the first post, where the RFID head writes information about the operations performed to the tag on the component. After write, the manipulator moves the component from the table to the belt or to the preset position.

Collecting of data from sensors, RFID system, and pneumatic drive management will be implemented using IO-Link technology, which will provide both process and diagnostic data throughout the program run. As an example, additional functions can be provided with the IO-Link valve island. In addition standard switching of coil, it is possible to set 32 bits counter on

individual coils, reset of this counters, set the switch point on the counter, after which the information about reaching the specified number of switches is sending, the short-circuit indication on individual coils, Process and diagnostic data will be accessed through the user interface.

Module extension and connection to system FMS 500. After completing the described basic functionality, the module will be expanded by additional features, devices, and technologies. The main extension should be to connect this stand-alone station into the upgraded FMS 500 system, where the PLC S7-300 will be replaced by PLC S7-1500, the Profibus communication bus replaces the Profinet bus and IO-Link technology will be integrated at the individual stations, just like the machining module.

The interconnection of the individual stations will be provided by the Profinet industrial bus which is normally realized with a metallic cable (twisted pair) with RJ-45 or M12-180 terminals. A possible extension is the implementation of the IWLAN (Industrial Wireless Local Area Network) module that provides wireless industrial communication over an AP (Access point) and a client connection. This extension can be used to communicate the FMS 500 with another system or with a higher level controller (PC), which therefore may not be in the immediate vicinity of the system or does not need to be connected with a bus cable.

Another extension can be sending and storing data to cloud services, For example MindSphere from SIEMENS. Thanks to this technology they are processed and shared. Last but not least, the expansion of IO-Link technology features.

Conclusion. Contact with the latest trends and mastering the most advanced technologies in the field of industrial automation is the only way to prepare future engineers for their work and to provide them sufficient theoretical knowledge, but especially practical and related skills, for their better use in the labor market. The way this task can be handled is real work with devices whose features and capabilities fit into the concept of Industry 4.0. The development of these devices is very progressive and it is therefore necessary to modernize or replace the old technologies and equipment with new ones. That's why we've decided to upgrade and revitalize the FMS 500 line and add a whole new module.

The main objective of this article was to approach the design of the Machining Module with Industry 4.0 elements for the Modular Production System FMS 500. This design described the design of the given module with the deployment of the individual components whose type and parameters were described. The functions and purpose of the module were also described, as well as its functional capabilities in terms of diagnostics. Last but not least, we have outlined how this module could be further expanded and modernized in the future to get even closer to the Industry 4.0 concept.

Acknowledgement

This work has been supported by the Slovak Grant Agency KEGA 054 TUKE-4/2016 Innovation of teaching courses with a focus on automation in response to the demands of industry and services.

References

1. ŠIMŠÍK, Dušan - GALAJDOVÁ, Alena - RÁKAY, Róbert - Intenzifikácia výskumu a prepojenia na prax inováciou laboratórií - 2016. In: ARTEP 2016 : Automatizácia a riadenie v teórii a praxi. - Košice : TU, 2016 S. 52-1-52-10. - ISBN 978-80-553-2474-6.
2. ŠIMŠÍK, Dušan - GALAJDOVÁ, Alena - ŠEMINSKÝ, Jaroslav - RÁKAY, Róbert - VIŠŇOVSKÝ, Martin - Inovácia študijného programu automatizácia a riadenie strojov a procesov v reakcii na požiadavky priemyselnej praxe – 2016, In: ARaP 2016. - Praha : MM publishing, 2016 P. 79-82. - ISBN 978-80-906310-1-4.
3. VIŠŇOVSKÝ, MARTIN - GALAJDOVÁ, ALENA - Prepojenie PLC a IO-Link technológie ako súčasť Industry 4.0 - 2017. In: Novus Scientia 2017. - Košice : TU, 2017 S. 200-205. - ISBN 978-80-553-3080-8.

4. MPS® 500-FMS: Flexible production – compatible, modular and versatile, [on line], [cit. 2018-01-14]. Dostupné z: <http://www.festo-didactic.com/int-en/learning-systems/mps-the-modular-production-system/mps-500-fms/mps-500-fms-flexible-production-compatible,modular-and-versatile.htm?fbid=aW50LmVuLjU1Ny4xNy4xOC44NTUuNDI2MQ>.

УДК 331.103.1:004

Мартин Вишньовски, Роберт Ракай, Алена Галайдова, Душан Шимшик

ПРЕДСТАВЛЕННЯ МОДУЛЯ ЕКСПЕРИМЕНТАЛЬНОГО РОБОЧОГО МІСЦЯ НА ОСНОВІ ПЛАТФОРМИ INDUSTRY 4.0

Актуальність теми дослідження. Нові сучасні тенденції в кабельному промисловому зв'язку та обміні даними спрямовані на впровадження нових стандартів зв'язку, протоколів і зниження витрат. Зв'язок в кожній автоматизованій системі має визначальне значення. Функції цих систем дуже важливі для правильного функціонування автоматизованої системи.

Постановка проблеми. При проектуванні сенсорних і виконавчих систем автоматизації та для налагодження зв'язку між різними пристроями, розробники вирішили проблему за допомогою стандартизованого зв'язку, такого як технологія IO-Link. Ці комунікаційні технології разом з промисловою шиною створюють рішення для сучасного зв'язку з великою кількістю переваг, таких як швидкий дизайн і діагностика, уніфікований інтерфейс, зменшення вартості і робочого часу.

Аналіз останніх досліджень і публікацій. Для підготовки цієї статті ми проаналізували різні рішення для зв'язку між давачами і виконавчими механізмами, різні системи управління і механічні рішення. Ми використовували знання з наших попередніх експериментів і вибрали оптимальні компоненти та системи для нашого проекту.

Виділення недосліджених частин загальної проблеми. Є багато різних типів датчиків, виконавчих механізмів, комунікаційних інтерфейсів і промислових шин. Обсягу однієї статті недостатньо, щоб описати їх повністю. Ось чому ми описали лише ті, які будуть використовуватися.

Постановка завдання. У цій статті описується проект механічного модуля для модульної лабораторної системи FESTO FMS 500. Цей модуль буде фізично реалізований у межах активізації та модернізації лабораторної системи FMS 500 в Департаменті автоматизації, управління та людино-машинної взаємодії.

Виклад основного матеріалу. Ми слідуємо тенденціям промислової автоматизації та вимогам 4-ї промислової революції. З цієї причини ми використовуємо технологію IO-Link в поєднанні з Profinet для зв'язку з датчиками й виконавчими механізмами.

Висновки відповідно до статті. Основна мета цієї статті – запропонувати конструкцію механічного модуля з елементами Industry 4.0 для модульної виробничої системи FMS 500. У цьому проекті описуються окремі компоненти, які будуть використовуватися. Також описані функції та призначення модуля, а також його функціональні можливості з точки зору діагностики.

Ключові слова: автоматизація; управління; PLC; IO-Link; Cloud; бездротовий зв'язок; пневматичні системи; Industry 4.0.

Рис.: 8. Бібл.: 15.

Martin Visnovsky – PhD student, Technical University of Kosice (9 Letna str. , 040 01, Košice, Slovak Republic).

E-mail: martin.visnovsky@tuke.sk

Robert Rakay – scientific-research employee, Technical University of Kosice (9 Letna str. , 040 01, Košice, Slovak Republic).

E-mail: robert.rakay@tuke.sk

Scopus Author ID: 56922070700

Alena Galajdova – Deputy Head of Department, Associate Professor, Technical University of Kosice (9 Letna str. , 040 01, Košice, Slovak Republic).

E-mail: alena.galajdova@tuke.sk

Scopus Author ID: 6506796741

Dusan Simsik – Head of Department, Full Professor, Technical University of Kosice (9 Letna str. , 040 01, Košice, Slovak Republic).

E-mail: dusan.simsik@tuke.sk

Scopus Author ID: 6602121842