

UDC 624.01

DOI: 10.25140/2411-5363-2019-3(17)-82-88

*Patrik Šarga, Adrián Kollár***DESIGN AND REALIZATION OF MYRIO CONTROLLED ROBOTIC CAR**

Urgency of the research. Human safety comes first. Therefore, human activity in many areas is being replaced by machines. In many cases, this replacement comes in the form of robotic cars that are sent to places inaccessible or dangerous to humans. The use of robotic cars starts from the smallest models for inspection of pipelines, confined spaces, sewers, etc., to larger and more perfect cars that are able to carry more weight and thus more electronics and robotic parts, to overcome difficult terrain, unevenness, obstacles and replace the work of a humans, which can be life-threatening. Robotic cars for the exploration, search and destruction of explosives are a great example.

Target setting. The goal of the research was to create inspection robotic car controlled by MyRIO device.

Actual scientific researches and issues analysis. When designing the model and preparing this paper, we took into account both current sources – publications and papers dealing with the current state of development of the inspection robotic cars as well as existing robotic car solutions, which are widely available on the market.

Uninvestigated parts of general matters defining. Autonomous driving has not been addressed at this stage, but can be carried out in further research.

The research objective. The purpose of this article is to explain how a robotic car can be built using MyRIO hardware and LabVIEW software.

The statement of basic materials. In our work were used components from National Instruments. Specifically, MyRIO device and LabVIEW software.

Conclusions. The robotic car's construction was designed in Solidworks. The control system for computer was programmed in the LabVIEW environment, and its specific variables enabled sharing with other devices. In the end, the robotic car was controlled with a tablet in the Data Dashboard application. The functionality has been tested in the field and approved, that the inspection robotic car was ready for use in practice.

Keywords: robotic car; inspection robot; MyRIO; LabVIEW.

Fig.: 15. References: 12.

Introduction. Our goal was to create a functional inspection robotic car capable of operating in the field under various conditions. The operation is programmed in LabVIEW using the MyRIO control unit located in the car. A remote control is done using the Data Dashboard application on the tablet. Being an inspection robot, a very important part of its equipment is a webcam placed on the car, capable of transmitting images directly to a computer (tablet) and enabling the user to view the ongoing survey. If the robotic car operates at night, the connected LED lights will provide enough illumination to continue the survey. The research activity also includes two optical sensors for measuring the distance to the objects of inspection.

The robotic car operation is programmed in LabVIEW and all data is transferred directly to the computer via Wi-Fi, allowing the user to control the car and all its components in real-time. The user interface works through the Data Dashboard application installed on a tablet.

Design of the robotic car controlled by MyRio. The realisation was divided into two parts, construction and programming. First, we created the design of the inspection robotic car in Solidworks software (Fig. 1, 2, 3, 4, 5, 6) [1]. According to the design we made individual components and together with the purchased parts we assembled them into a physical solution.

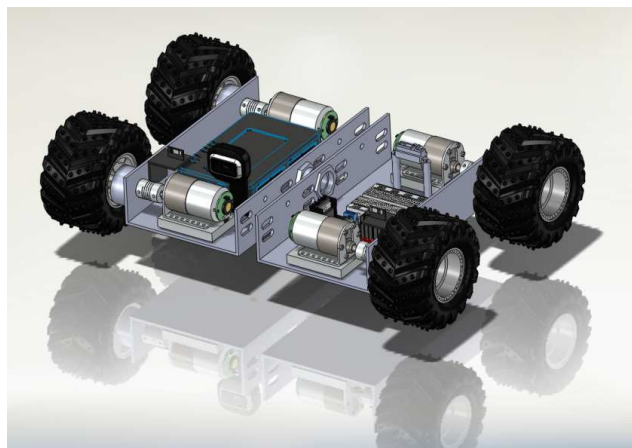

Fig. 1. Design of the robotic car in Solidworks

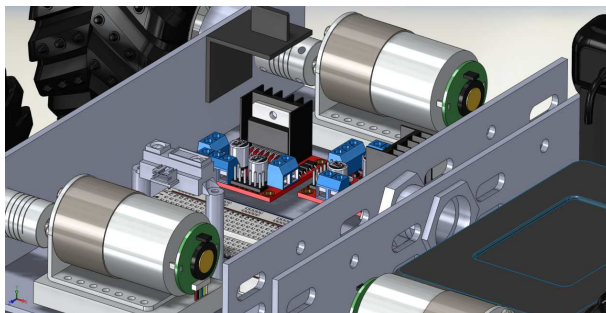

Fig. 2. Motors, optical sensor, H-bridges and contact field modeled in Solidworks

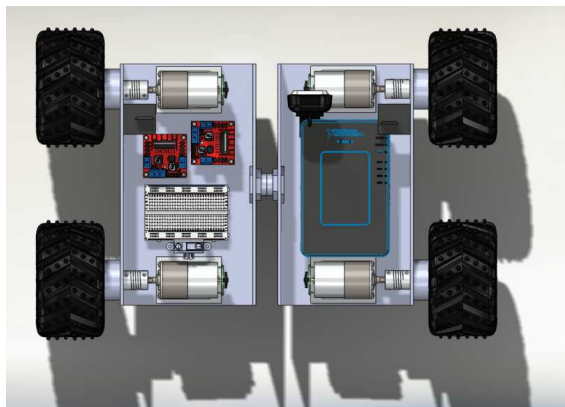

Fig. 3. Top view of modeled robotic car

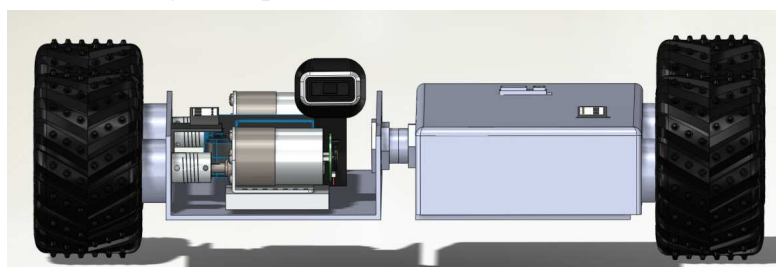

Fig. 4. Front view of modeled robotic car

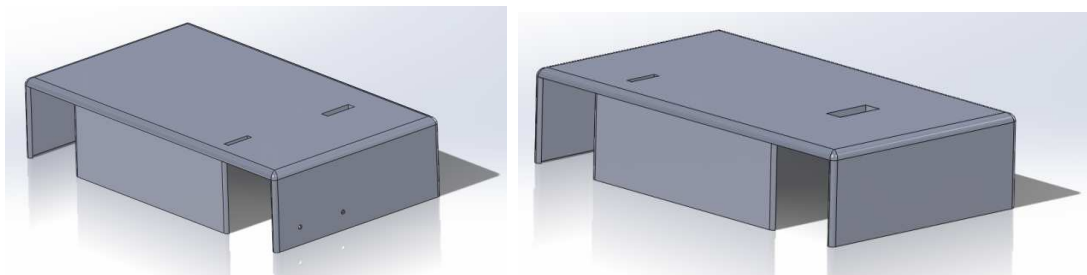

Fig. 5. Design covers for the sides of the car

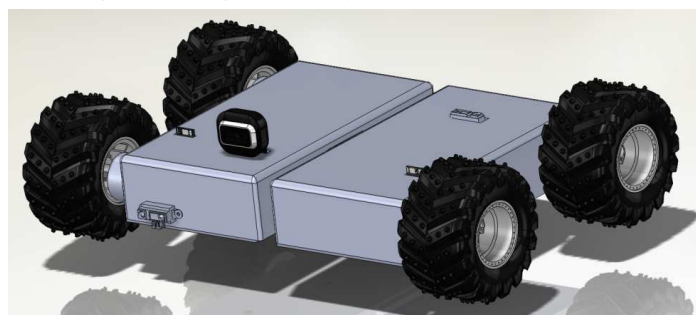

Fig. 6. Final model of the car with covers

The centre of the car is the National Instruments MyRIO control unit (Fig. 7). It is a portable reconfigurable stand-alone unit that is primarily used to design control systems in robotics and mechatronics. The basic model NI MyRIO-1900 offers the possibility to connect several analogue inputs (AI) and outputs (AO), digital inputs and outputs (DIO), connection to audio devices, USB port and connection to the power supply. The device also includes an 802.11b, g, n wireless connection. Fig. 7 shows the MyRIO control unit with accessories [2] [3].

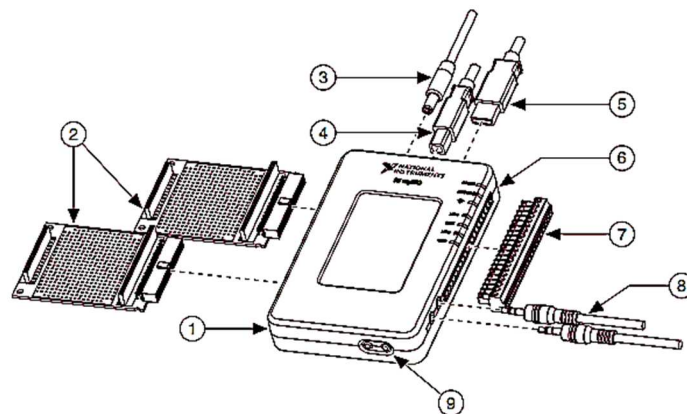

Fig. 7. NI myRIO 1900 [3]:

1 – NI myRIO-1900, 2 – myRIO Expansion Port (MXP) Breakouts, 3 – Power Input Cable, 4 – USB Device Cable, 5 – USB Host Cable, 6 – LEDs, 7 – Mini System Port (MSP) Screw-Terminal Connector, 8 – Audio In/Out Cables, 9 – Button0

The programming part deals mainly with the design and implementation of a program for driving the car forward, backward and modifying these movements such as moving forward and right, forward and left or fast turning - all wheel rotation (4WD). The main program is complemented by subprograms for the robot's optical sensors, LEDs and webcam. The software solution was designed and implemented in LabVIEW environment.

LabVIEW is a graphical programmable language that uses icons instead of structured text to simplify application programming. LabVIEW uses a programming data flow, which determines the execution of commands. LabVIEW program consists of the user interface in which the application is controlled and the block diagram in the background that manages the application. [4], [5].

Realisation of the inspection robotic car. The inside of the car consists of the following components: two H-bridges (Fig. 8), contact field, two optical sensors, MyRIO control unit, LED lights and more. [6], [7].

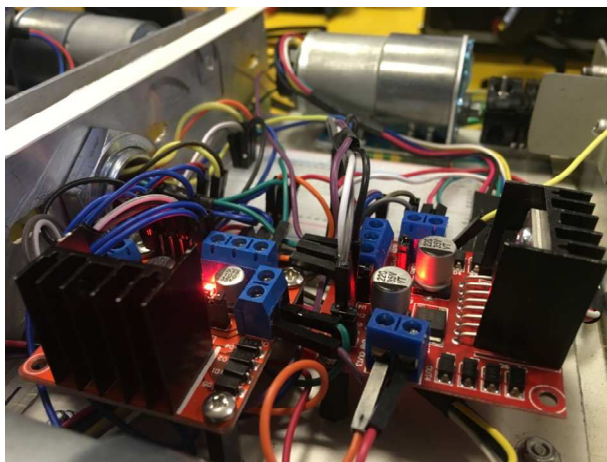

Fig. 8. H-bridge connection

TECHNICAL SCIENCES AND TECHNOLOGIES

After connecting H-bridges, motors [8] and encoders, we added sensors and LED lights. We used optical distance sensors from Sharp and the lights were made of USB LED lights connected to 5V.

We installed all these components together with the control unit and the webcam [9] in the car. In the last step we connected all components to the batteries. Motors require optimal 12V DC voltage. We connected four motors with battery to the H-bridge and the 5V bridge control and power is provided by the MyRio device. The wiring diagram is shown in Figure 9.

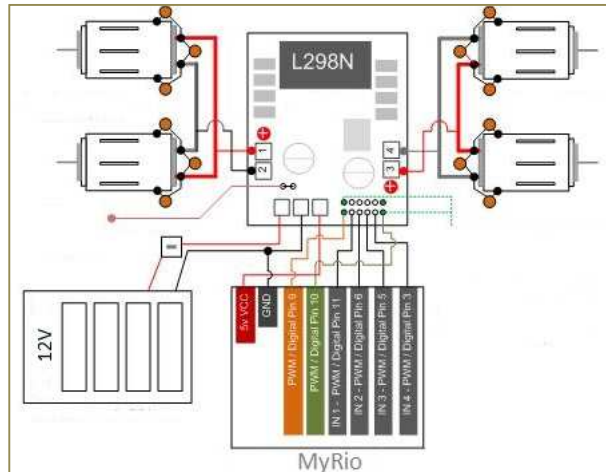

Fig. 9. H-bridge connection to four motors

The final realization of the car is shown in the following figures (Fig. 10).

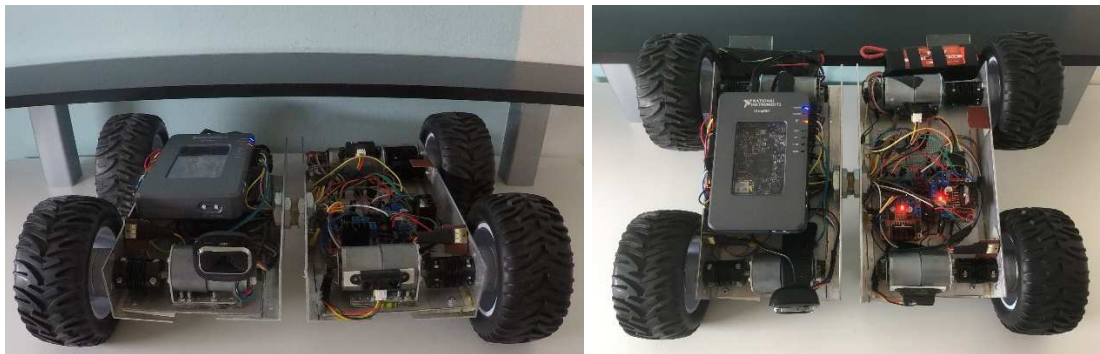

Fig. 10. Final robotic car without cover, front and top view

Design of the robotic car control software. The control software was created in the Lab VIEW environment, complemented by Real-Time, Vision & Acquisition module and MyRio toolkit [4], which allow us to use pallets and functions directly associated with MyRIO.

After creating the project, we started to insert functions and commands into the block diagram (Fig. 11). In the beginning, we programmed the drives, and it was necessary to deal with the motion logic using PWM signals and the H-bridge [10]. A chassis of the car has four DC motors with encoders, which are connected to two H-bridges. Each bridge thus controls two engines on one side of the car. These motors may, in certain cases, operate as a whole, but each one of these motors is individually controlled based on the input values from the respective encoder. Each motor has its own PID controller to achieve the desired behavior and in case of external influences, each wheel can autonomously regulate. Such operation has the greatest advantage when moving the car on an inclined plane (the left side will be placed higher than the right side or vice versa). The H-bridge has two inputs for motor activation. We can activate these inputs by interconnecting them to achieve permanent operation of the motors, or to supply signals from the MyRIO device and control the motors manually.

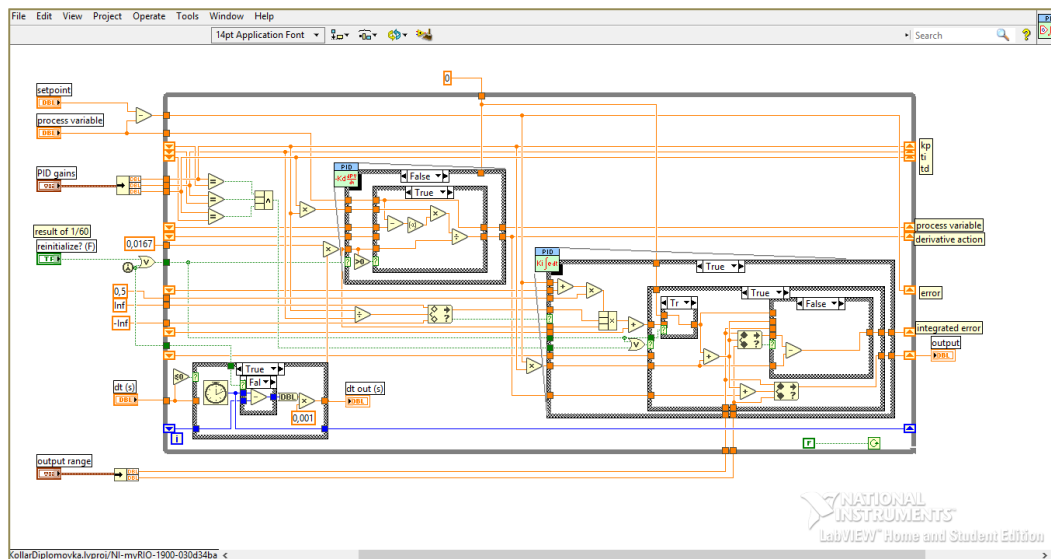

Fig. 11. Example of the block diagram

The next step in the programming was to design and customize the user interface, which will make control complex and intuitive.



Fig. 12. User interface

In Fig. 12 we can see the final user interface for controlling the robotic car on a computer. This environment includes:

- 1) four sliding panels to control the speed and wheel rotation;
- 2) six buttons: forward/reverse button, 4WD drive activation, forward/side drive activation, LED lights on/off, PID controller restart, tablet control sharing function, and stop button, which stops all ongoing operations;
- 3) transferring images from a webcam to a computer;
- 4) a graph showing the behavior of the motors after PID control;
- 5) two indicators to show the distance of objects from the car;
- 6) four engine speed indicators.

In the final step, we created a remote control environment for iOS using a tablet (iPad). This control was implemented using the Data Dashboard application [11], which allows us to manage shared values from a computer in real time in a tablet. These values are created as variables on the computer and placed in a diagram. It is then linked using a tablet library that is connected to the same network (in this case MyRio).

The resulting tablet control application is shown in Fig. 13. The aim was to create a simplified version of the control environment (Fig. 14).

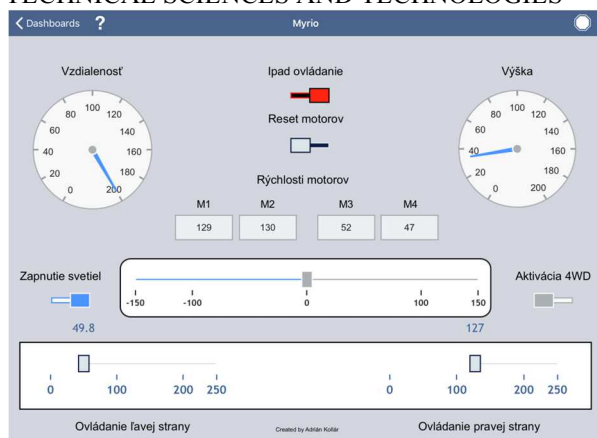

Fig. 13. Simplified user interface for tablet



Fig. 14. The completed robotic car controlled by a tablet

Testing. After the robotic car was completed, it was necessary to test the functionality of the whole device under various conditions. One of the tests was the inspection of the chassis on the automobile, which can be seen in Figure 15. When testing the functionality of the inspection robotic car, undesirable conditions were not detected and the full functionality of the proposed solution was confirmed.



Fig. 15. Final robotic car during chassis inspection

Conclusions. The aim was to create an inspection robotic car, controlled by MyRio. The car was constructed according to the design created in Solidworks. In the next step, we created a control in the LabVIEW environment, which allows us to control the car using a computer. After programming the control via the computer, some variables were set to share with other devices. This allowed the remote control of the robotic car with the tablet in the Data Dashboard app. The car was field-tested and is therefore ready for inspection of car chassis, but also for field research [12].

Acknowledgement. This work was supported by grant project VEGA 1/0330/19.

References

1. Types of chassis for robotic cars (2019), Retrieved from <https://www.intorobotics.com/best-chassis-to-build-an-outdoor-robot-on-wheels/> [in English].
2. Myrio manual (2019), Retrieved from <http://www.ni.com/academic/students/learn-rio/applications/> [in English].
3. National Instrument (2019), User guide and specifications NI myRio-1900, Retrieved from <http://www.ni.com/pdf/manuals/376047c.pdf> [in English].
4. National Instrument (2019), LabVIEW manual, Retrieved from <http://www.ni.com/academic/students/learn-labview/> [in English].

5. National Instrument (2019), Getting started with compactRIO and LabVIEW, Retrieved from <http://www.ni.com/pdf/manuals/372596b.pdf> [in English].
6. Fitzgerald, Higginbotham, Grabel (1975), Basic electrical engineering, Boston, 621p. [in English].
7. Michaeli, Linus (2012), Elektronické súčiastky a obvody, Košice, 224p. [in Slovak].
8. Pololu Corporation (2019), metal gearmotors, item 2824, Retrieved from <https://www.pololu.com/product/2824> [in English].
9. Microsoft LifeCam HD-3000 (2019), product T3H-00013, Retrieved from <https://www.microsoft.com/accessories/sk-sk/products/webcams/lifecam-hd-3000/t3h-00012> [in Slovak].
10. Divis, Chmelikova, Zdrálek (2005), Logické obvody, Ostrava, 152p. [in Czech].
11. National Instruments (2019), Data Dashboard application, Retrieved from <http://www.ni.com/tutorial/13757/en/> [in English].
12. Kollar, Adrián (2019): Vytvorenie autíčka riadeného pomocou myRIO, Košice, [in Slovak].

УДК 624.01

Патрик Шарга, Адриан Коллар

ПРОЕКТУВАННЯ ТА РЕАЛІЗАЦІЯ РОБОТИЗОВАНИХ АВТОМОБІЛІВ, ЯКИМИ КЕРУЄ MYRIO

Актуальність теми дослідження. Безпека людини на першому місці. Тому діяльність людини в багатьох сферах замінюється машинами. У багатьох випадках ця заміна здійснюється роботизованими автомобілями, які відіграють в місті, недоступні або небезпечні для людини. Використання роботизованих автомобілів починається від найменших моделей для огляду трубопроводів, обмежених просторів, каналізації тощо, до більших і досконаліших машин, які здатні перевозити більше ваги, а отже, більше електроніки та робототехнічних деталей, для подолання складної місцевості, нерівностей, перешийки та замінити людину на роботах, небезпечних для життя. Роботизовані машини для розвідки, пошуку та знищення вибухових речовин – прекрасний приклад.

Постановка проблеми. Метою дослідження було створити оглядовий роботизований автомобіль, керований пристроєм MyRIO.

Аналіз основних досліджень і публікацій. Розробляючи модель та готуючи цю роботу, ми врахували як сучасні джерела - публікації та статті, що стосуються сучасного стану розвитку оглядових роботизованих машин, так і існуючі рішення щодо роботизованих автомобілів, які широко доступні на ринку.

Виділення недосліджених частин загальної проблеми. На цьому етапі автономне керування не розглядалося, але може бути здійснене в подальших дослідженнях.

Постановка завдання. Мета цієї статті – пояснити, як можна побудувати роботизований автомобіль за допомогою апаратних засобів MyRIO та програмного забезпечення LabVIEW.

Виклад основного матеріалу. У нашій роботі були використані компоненти від National Instruments. Зокрема, пристрій MyRIO та програмне забезпечення LabVIEW.

Висновки відповідно до статті. Конструкція роботизованого автомобіля була розроблена в Solidworks. Комп'ютерна система управління була запрограмована в середовищі LabVIEW, а її конкретні змінні дозволяють ділитися з іншими пристроями. Зрештою, роботизований автомобіль керувався планшетом у додатку Data Dashboard. Функціональність була перевірена на місцях і підтверджено, що оглядовий роботизований автомобіль був готовий до використання на практиці.

Ключові слова: роботизований автомобіль; оглядовий робот; MyRIO; LabVIEW.

Рис.: 15. Бібл.: 12.

Patrik Šarga – Doctor of Technical Sciences, Associate Professor, Department of Automation and Human Machine Interactions, Faculty of Mechanical Engineering, Technical University of Košice (Letna 9, 04200 Košice, Slovak Republic).

Патрик Шарга – доцент, кандидат технічних наук, факультет механічної інженерії, Технічний університет Кошице (Letna 9, 04200 Košice, Slovak Republic).

E-mail: patrik.sarga@tuke.sk

Scopus Author ID: 15128102900

Adrián Kollár – student, Department of Automation and Human Machine Interactions, Faculty of Mechanical Engineering, Technical University of Košice (Letna 9, 04200 Košice, Slovak Republic).

Адриан Коллар – студент, факультет механічної інженерії, Технічний університет Кошице (Letna 9, 04200 Košice, Slovak Republic).

E-mail: adrian.kollar@student.tuke.sk