

РОЗДІЛ III. ЕНЕРГЕТИКА, ЕЛЕКТРОТЕХНІКА ТА ЕЛЕКТРОМЕХАНІКА

UDC 621.314.1

DOI: 10.25140/2411-5363-2019-3(17)-168-174

Dmitriy Alekseevskiy, Olena Mikhailutsa, Andriy Pozhuyev

AVERAGED MODEL OF A BOOST-TYPE PULSE DC CONVERTER

Urgency of the research. In the present paper, the questions of synthesis and application of the mathematical model of a boost-type DC converter, which has found widespread application in modern electrical devices and complexes, are considered.

Target setting. Modeling of electrical complexes, which include semiconductor converters together with electromechanical, thermodynamic and other relatively slow processes, is faces the problem of a significant increase in simulation time. One way to solve this problem is to use the mathematical description of the semiconductor converter in the values averaged over the period of operation of the semiconductor switch.

Actual scientific researches and issues analysis. In publications on this topic over the past few years, averaged models of DC converters of all basic types have been proposed. Both continuous and intermittent current modes are considered.

Uninvestigated parts of general matters defining. In the models described in the publications, the continuous and intermittent current modes are considered as separate models in which ideal semiconductor switches are used. In addition, the adequacy of the models used is not given enough attention.

The research objective. The objective of this work is to synthesize an averaged mathematical model of a boost-type DC converter, which would take into account the effect of direct voltage drops on the circuit elements in continuous and intermittent current modes, as well as assess the adequacy of applying the averaged approach.

The statement of basic materials. In the article a description of an averaged mathematical model of a boost-type DC converter, which takes into account direct drops on the circuit elements and provides simulation both in continuous and intermittent current mode, is given. To confirm the performance and assess the adequacy of the proposed model, a joint simulation was performed using the proposed and reference (circuit) model, and its comparative analysis is given.

Conclusions. The results of the comparative analysis confirmed the adequacy of the proposed model and revealed the occurrence of an error in the intermittent current mode, and also determined its cause.

Keywords: Boost-type pulse DC converter; visual modeling; mathematical model adequacy.

Fig.: 4. References: 10.

Urgency of the research. The creation of complicated modern technical objects, such as electrotechnical complexes with semiconductor converters, is impossible without a qualitatively conducted modelling period. The need for efficient control algorithms synthesis for electrical systems, including a boost-type pulse DC converter, results from optimization of device operation. The creation of a mathematical model can significantly simplify the process of developing electronic systems in modelling period. The enhancing of electrical systems modelling process is achieved by visual modelling of a boost-type pulse DC converter. In addition, the form of the visual-structural representation of mathematical dependencies describing such devices is not only a way of describing the computation algorithm, but also contributes to the understanding of electromagnetic processes in it, which is important when training the technology specialists.

Target setting. Nowadays, there is a common problem of creating system models that include subprocesses with different rates of modelling optimization time. A particular interest is paid to electrical system structures, that include semiconductor converters along with electromechanical, thermodynamic and other relatively slow processes. The creation of an adequate model by means of circuit simulation is quite a challenge. It is much simpler and more efficient to syntheses for controlling electrical systems, which include a boost-type pulse DC converter, to carry out the structural modelling. Thus, the article solves an actual scientific problem regarding the creation of an algorithm that simulates the direct voltage drop process in semiconductor device switches. The developed algorithm is a constituent part of general simulation model of the boost-type pulse DC converter.

Actual scientific researches and issues analysis. Widespread use of pulsed semiconductor converters in various modern electrical systems requires further improvements in the modeling processes. In recent decades, to increase the accuracy, a variety of tools (models, techniques and algorithms) have been developed, as well as software to enhance the modelling process for pulse semiconductor converters of three main types.

Notably, that many works of domestic and foreign scientists are devoted to the research of such issues. For example, in [1], a mathematical model of a boost-type pulse DC converter with pulse-width modulation is considered, which allows investigating the dynamics of the converter operation to ensure a scientifically based choice of the controller parameters. However, in the considered model, ideal switches are used, and the parameters of CVC (current-voltage characteristic) switches are taken into account only implicitly in equivalent resistance. This makes it difficult to parameterize the model using passport semiconductor switch data.

Works [2] and [3] consider averaged models of pulse semiconductor converters of three main types, based on their structural pulse models. But they don't pay respect to voltage drops in power diode and in transistor of the model. It is noted that a common practice today is the creation of computer models using standard modelling tools, for example, MATLAB Simulink, and the subsequent conduct of a model experiment to select device parameters, resulting in a performance decrease.

To overcome this problem, the work [4] substantiates averaged structural models of an inverting DC pulse converter. The described structural averaged models are not intended for simulation of a semiconductor converter modelling and cannot be used as an integral part of the model of an electrical engineering complex.

In [5], a description of the averaged mathematical model of a boost-type pulse DC converter is considered. Unfortunately, this model does not take into account the parameters of semiconductor switches and uses their ideal models. In addition, the paper presents only a mathematical description of an averaged model of converter and does not pay attention to organization of computational process.

Further, in [6], a mathematical model of a pulse converter with nonlinear external characteristics is considered. The model is presented in state variables on different parts of smoothness and makes it possible to regard the nonlinear properties of the transducer of the first kind in the modelling period. In the converter equivalent circuit, losses in switches are considered implicitly - as the equivalent loss resistance in the converter.

In [7], an averaged model of a DC pulse converter is also proposed. The reliability of the presented model is correlated with a model built by the author on the Kirchhoff's laws basis, and not with a circuit model. In this regard, the results of comparative modelling raise doubts, in particular, the presence of negative values of the inductance current during an oscillatory transient process.

In [8], the given approach clarifies the averaged mathematical models of main types of DC converters, which were described by the author earlier in [2]. This description, as a clarification, includes consideration of direct voltage drop on only one power switch – the power diode, and the voltage drop across the power transistor is not taken into consideration.

Uninvestigated parts of general matters defining. Nowadays, there are no domestic software systems conducting semiconductor converters modelling as part of electrical engineering complex. The mathematical basis of such a software should be an object simulation model itself and the pulse DC converter as a single whole. To reveal the above general issue, it is necessary to solve the problem of constructing an algorithm for modelling of just such systems being developed. It should be noted, in the authors' works considered in the review devoted to the problem of pulse voltage converters modelling, insufficient attention is paid to the analysis of the adequacy and accuracy of simulation results. Meanwhile, the developer of control systems with pulse voltage converters, would be interested in having an idea of the accuracy assessment of results reproduced by the model.

The research objective. To analyze the problem of growing modelling time caused by a large number of integrating system iteration of differential equations during each period of semiconductor switch operation, the use of an averaged mathematical model (with the example of a mathematical synthesis model of boost-type pulse DC converter) is considered.

The statement of basic materials. In the classical pulse DC converter scheme of boost type (Fig. 1), the averaged values of electrical quantities for the switching period of power switches are taken as state parameters of the model.

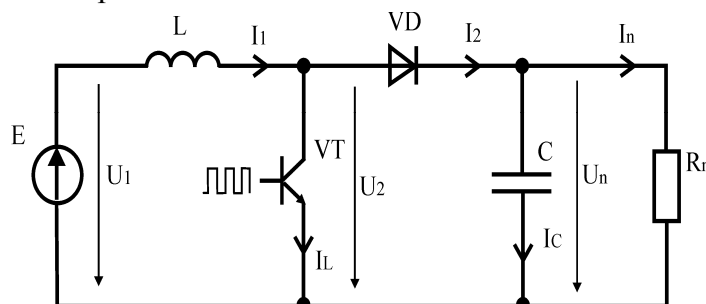

Fig. 1. Diagram of boost-type pulse DC converter

Voltage of the converter (U_n) output is determined by the charge on the output capacitor, the integral value of which is described by the following expression:

$$U_n(t) = \frac{1}{C} \int_0^t I_C(\tau) d\tau + U_n(0), \quad (1)$$

where C is the capacitance of the output capacitor, $U_n(0)$ is the initial voltage at the pulse DC converter output.

Herewith, the load current with a known resistance R_n is found according to Ohm's well-known law, which is written in the following form:

$$I_n(t) = \frac{1}{R_n} \cdot U_n(t). \quad (2)$$

The value of the current via the diode (I_2) is proportional to the current inductance (I_1) taking into account the fill factor of the diode open state γ_{VD} :

$$I_2(t) = \gamma_{VD}(t) \cdot I_1(t). \quad (3)$$

The inductance current is determined by the magnetic field energy of the inductor, the integral form of which is given by the following expression:

$$I_1(t) = \frac{1}{L} \int_0^t U_L(\tau) d\tau + I_1(0), \quad (4)$$

where L – is the value of input inductance, $I_1(0)$ is the initial value of current inductance.

Voltage on the transistor switch is proportional to the voltage on the output capacitor, taking into account the fill factor of the diode open state:

$$U_2(t) = \gamma_{VD}(t) \cdot U_n(t). \quad (5)$$

The fill factor of the diode open state depends on the current mode and is determined (in continuous or intermittent current mode) by the following expression:

$$\gamma_{VD}(t) = \begin{cases} \frac{U_1(t) \cdot \gamma_{VT}(t)}{U_n(t) - U_1(t)} & \text{when } I_1(t) < \frac{U_1(t) \cdot \gamma_{VT}(t) \cdot T(t)}{2 \cdot L} \\ 1 - \gamma_{VT}(t) & \text{when } \frac{U_1(t) \cdot \gamma_{VT}(t) \cdot T(t)}{2 \cdot L} \leq I_1(t) \end{cases} \quad (6)$$

where T – is the switching period of the transistor, and the fill factor must satisfy the following condition:

$$0 < \gamma_{VD}(t) \leq \gamma_{VT}(t).$$

Using Kirchhoff's law, we determine the current of the output capacitor and the voltage across the inductance, the latter taking into account the losses in the switch elements and the inductance:

$$I_C(t) = I_2(t) - I_n(t) \tag{7}$$

$$U_L(t) = U_1(t) - U_2(t) \cdot \gamma_{VD}(t) - U_{onVD} \cdot \gamma_{VD}(t) - R_{onVD} \cdot I_2(t) - U_{onVT} \cdot \gamma_{VT}(t) - R_{onVT} \cdot I_1(t) \cdot \gamma_{VT}(t) - R_L \cdot I_1(t), \tag{8}$$

where U_{onVD} , U_{onVT} – are direct voltage of the diode and the switch transistor, R_{onVD} , R_{onVT} – are their direct resistance, R_L – resistance, that considers losses in the inductance coil. The mathematical model with the above expressions (1) - (8) can be easy represented by the visual block diagram of a boost-type pulse DC converter (Fig. 2), where the blocks indicated by dotted lines are numbered in accordance to expressions (1) – (8).

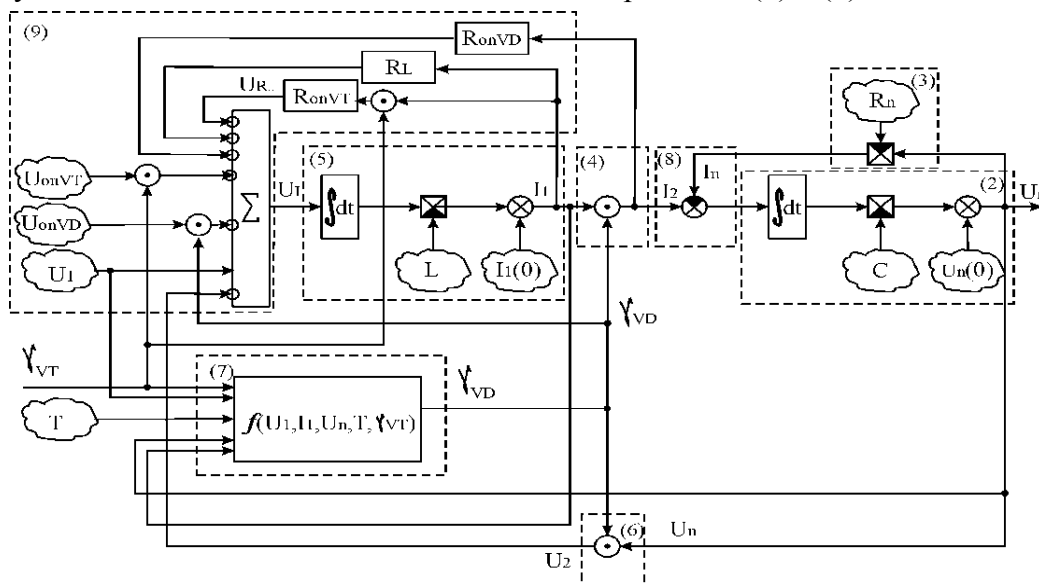

Fig. 2. Visual block diagram of a boost-type pulse DC converter

Researches. Adequate converter modelling, as an element of the system, needs a sufficiently large number of integration system iterations of differential equations during each period of semiconductor switch operation. Knowing that modern devices of converter equipment operate at tens and hundreds of kilohertz frequencies, the complex modelling throughout the entire transition process, with time constants from several seconds to several minutes, is associated with a huge total number of calculation iterations, and this, in its turn, leads to a significant increase of modelling time.

For example, the modelling of a high pressure lamp ignition controlled by a start-up device based on a boost-type pulse DC converter takes several hours, due to the fact that computational process also requires the numerical solution of transcendental equations. As it was mentioned above, the use of averaged models is a way to reduce the modelling time significantly.

A modelling of a boost-type pulse DC converter has been made in order to determine the coil current and capacitor voltage. For clarity and understanding of the essence of the proposed methodology, the results are compared at the circuit designed and structural levels, considering the participation of DC converter [9], [10].

According to the modelling results, dependencies of the coil current and the capacitor voltage on the operating time of the pulse converter were built (Fig. 3). The sawtooth curve corresponds to the circuit model, and the smooth curve corresponds to the average model. Comparison of the modelling results (Fig. 3) at the circuit designed and at the structural level shows a high degree of adequacy of the proposed model. The implementation of the model presented in the work allows significantly (more than three orders of magnitude) to reduce the modelling time. Means of modelling verify the adequacy of the resulting mathematical model. A comparative analysis was carried out by comparing the results of applying the circuit and average models at the output using identical low-pass filters.

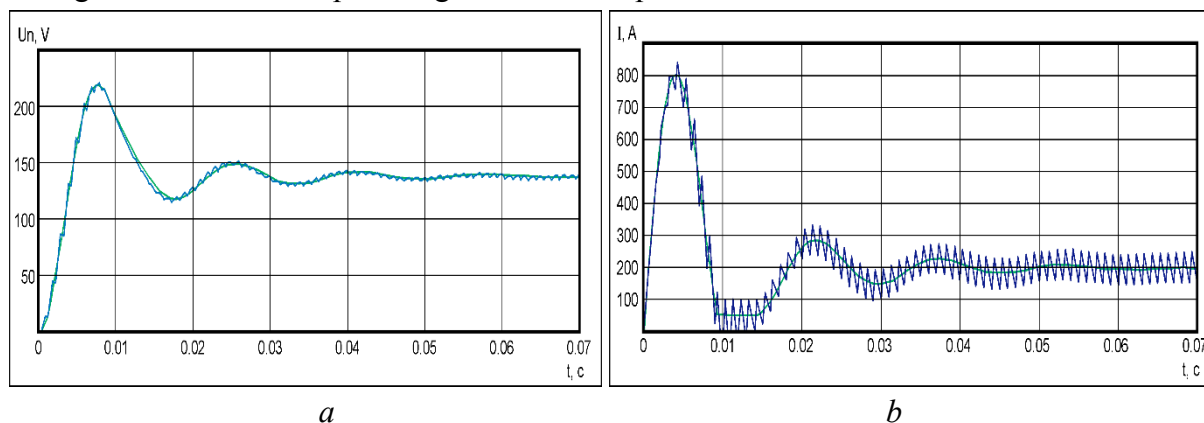

Fig. 3. The modelling results for two alternative models:
a – dependence of the output voltage; b – current dependence

According to the modelling results, dependencies of the coil current and the capacitor voltage on the operating time of the pulse converter were built (Fig. 3). The sawtooth curve corresponds to the circuit model, and the smooth curve corresponds to the average model. Comparison of the modelling results (Fig. 3) at the circuit designed and at the structural level shows a high degree of adequacy of the proposed model. The implementation of the model presented in the work allows significantly (more than three orders of magnitude) to reduce the modelling time. Means of modelling verify the adequacy of the resulting mathematical model. A comparative analysis was carried out by comparing the results of applying the circuit and average models at the output using identical low-pass filters.

For the model proposed in the paper, Figure 4a), we present the results of a model experiment to determine the values of the relative modelling error. As in the previous review, a circuit model of a boost-type pulse DC converter was taken as a reference model. To compare the moments of transition process in Figure 4b), the smoothed temporal characteristics of the inductance current in discontinuous current section is given.

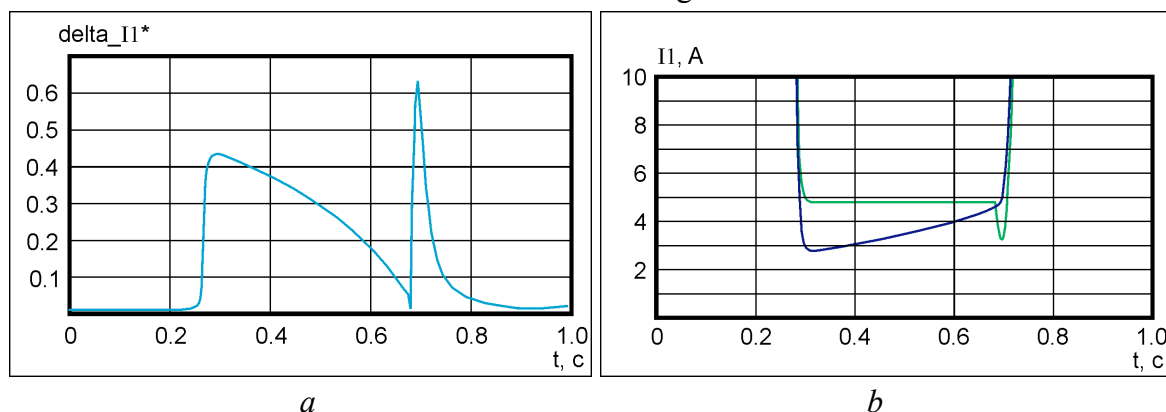

Fig. 4. The research results of the modelling relative error values
a – the relative modelling error; b – characteristics of the inductance current in discontinuous current section

TECHNICAL SCIENCES AND TECHNOLOGIES

The analysis of the graphs shows that the greatest modelling error falls on the discontinuous current mode, with peak values corresponding to moments of transition from the continuous current mode to the discontinuous mode and vice versa. The analysis of cause-and-effect relations structure conducted in this work reveals the presence of a rather rigid negative feedback on inductance current. It occurs in a natural way when applying the procedure for determining the regime of "intermittent-continuous current" in the formula (6). This procedure adequately reproduces transition moments; however, after the model reaches the discontinuous current mode, the computational algorithm begins to stabilize the value of choke current at the threshold value (Fig. 4). At the same time, in the reference model, inductance current varies with time due to a change in the voltage on capacitance. The voltage on capacitance thus determines magnitude of the error in the discontinuous current mode.

It should be noted that this problem seems to be present in implementation of models in works of other authors. For example, in [5], latent negative feedback on inductance current can be detected in the resulting system of model equations, although, as mentioned above, the accuracy of the averaged inductance current is not considered. This problem manifests itself only when the model is implemented on a PC and while organizing the computational flow, and its identification became possible only when applying a visual representation of the cause-and-effect relationships using a visual model.

Maximum error values and the nature of its change over time in sections of intermittent current depend on the parameters of the converter circuit. It should be noted that although it is quite large in relative values, in absolute value it does not exceed 1-2% of the nominal, which, in most cases, is acceptable for practical tasks. In the continuous current mode, the relative error averages only 0.6%. In connection with the above, the proposed model can be regarded as a sufficiently adequate one in relation to the main tasks of designing control systems for electrical systems, which include a boost-type pulse DC converter.

Conclusions. In present work, an actual scientific problem has been solved regarding the development of a boost-type pulse DC converter modelling algorithm. The scientific novelty of the work consists in improvement of boost-type pulse DC converter simulation model, which, unlike the existing ones, takes into account direct voltage drops on the device's semiconductor switches and in assessing the adequacy of the proposed model.

The presentation of an averaged mathematical model of boost-type pulse DC converter is a computational algorithm in a convenient, ready for use in practical form, since it is a complete description of computational process. The proposed modelling approach can be applied to other DC / DC converter circuits.

References

1. Andriyanov, A. I., Malakhanov, A. A. (2006). Mathematical modeling of the dynamics of a pulse type up-converter. *Bulletin of the Bryansk State Technical University*, 1(9), 61–69 [in English].
2. Belov, G. A. (2008). Structural models and the study of the dynamics of pulse converters. *Electricity*, 4, 40–49 [in English].
3. Belov G. A., Malinin A. V., Pavlova A. A. (2008). Structural dynamic models and frequency method for the synthesis of dual-circuit control systems of pulse converters. *Power Electronics*, 3, 98–106 [in English].
4. Belov, G. A., Serebryannikov, G. V., Semenov, Yu. M. (2013). Averaged structural dynamic models of an inverting pulse converter. *Practical power electronics*, 4(52), 28–35 [in English].
5. Kapustin, I. V., Lukashenkov, A. V. (2013). Structural dynamic models and frequency method for the synthesis of dual-circuit control systems of pulse converters. *News of TSU. Technical science*, 2, 126–135 [in English].
6. Andriyanov, A. I., Krasnov, N. A. (2013). Mathematical modeling of pulse voltage converters with nonlinear external characteristic. *Current Issues of Technical Sciences: Proceedings of the II Intern. scientific conf.* (pp. 28–31). Perm: Mercury [in English].
7. Mezhaikov O. G. (2015). Mathematical model of the down-converter voltage. *Young scientist*, 5, 171–176 [in English].

8. Belov, G. A. (2015). Linearization of averaged structures of dynamic models of pulsed DC converters in the discontinuous current mode. *Electricity*, 9, 55–64 [in English].
9. German-Galkin, S. G. (2001). *Computer simulation of semiconductor systems*. St. Petersburg [in English].
10. Chernykh, I. V. (2008). *Simulation of electrical devices in MatLab, SimPowerSystems and Simulink*. Moscow: DMK Press; SPb: Piter [in English].

УДК 621.314.1

Дмитро Алексієвський, Олена Міхайлуца, Андрій Пожуєв

УСЕРЕДНЕНА МОДЕЛЬ ІМПУЛЬСНОГО ПЕРЕТВОРЮВАЧА ПОСТІЙНОЇ НАПРУГИ ПІДВИЩУЮЧОГО ТИПУ

Актуальність теми дослідження. У статті розглядаються питання синтезу та застосування математичної моделі імпульсного перетворювача постійної напруги підвищуючого типу, який знайшов достатньо широке застосування в сучасних електротехнічних пристроях і комплексах.

Постановка проблеми. Моделювання електротехнічних комплексів, що мають у своєму складі напівпровідникові перетворювачі спільно з електромеханічними, термодинамічними й іншими відносно повільними процесами, постає перед проблемою значного збільшення часу моделювання. Одним із шляхів вирішення цієї проблеми є застосування математичного опису напівпровідникового перетворювача в усереднених, за період роботи напівпровідникового ключа, величинах.

Аналіз останніх досліджень і публікацій. У публікаціях на цю тему за останні кілька років запропоновані усереднені моделі перетворювачів постійної напруги всіх основних типів. Розглядаються, як режими безперервного, так і переривчастого струму.

Виділення недосліджених частин загальної проблеми. В описаних у публікаціях моделях режими безперервного й переривчастого струму розглядаються як окремі моделі, в яких використовуються ідеальні напівпровідникові ключі. Крім того, питанням адекватності застосовуваних моделей не приділено достатньо уваги.

Постановка завдання. Завданням цієї роботи є синтез усередненої математичної моделі імпульсного перетворювача постійної напруги підвищувального типу, яка враховувала б вплив прямих падінь напруги на елементах схеми в режимах безперервного й переривчастого струму, а також оцінка адекватності застосування усередненого підходу.

Виклад основного матеріалу. У роботі наведено опис усередненої математичної моделі імпульсного перетворювача постійної напруги підвищуючого типу, що враховує прямі падіння на елементах схеми і забезпечує моделювання як у режимі безперервного, так і переривчастого струму. Для підтвердження працездатності та оцінки його запропонованої моделі в роботі було проведено спільне імітаційне моделювання за допомогою запропонованої та еталонної (схемної) моделі й наведено його порівняльний аналіз.

Висновки відповідно до статті. Результати порівняльного аналізу підтвердили адекватність запропонованої моделі і виявили причину виникнення похибки в режимі переривчастого струму, а також визначили її причину.

Ключові слова: імпульсний перетворювач постійної напруги; візуальне моделювання; адекватність математичної моделі.

Рис.: 4. Бібл.: 10.

Alekseevskiy Dmitriy – PhD in Technical science, Associate Professor, Associate Professor of Electronic Systems department, Engineering Institute of Zaporizhzhya National University (226 Sobornyi Av., 69006 Zaporizhzhia, Ukraine).

Алексієвський Дмитро Геннадійович – кандидат технічних наук, доцент, доцент кафедри електронних систем, Інженерний інститут Запорізького національного університету (просп. Соборний 226, м. Запоріжжя, 69006, Україна).

E-mail: lasian2017@ukr.net

ORCID: <https://orcid.org/0000-0002-5787-6092>

ResearcherID: S-9538-2018

Mikhailutsa Olena – PhD in Technical science, Associate Professor, Associate Professor of Department of Automation Systems Software, Engineering Institute of Zaporizhzhya National University (226 Sobornyi Av., 69006 Zaporizhzhia, Ukraine).

Міхайлуца Олена Миколаївна – кандидат технічних наук, доцент, доцент кафедри програмного забезпечення автоматизованих систем, Інженерний інститут Запорізького національного університету (просп. Соборний 226, м. Запоріжжя, 69006, Україна).

E-mail: elenamikhaylutsa7@gmail.com

ORCID: <http://orcid.org/0000-0003-2935-7997>

Scopus Author ID: 16407827200, 57210602000

Pozhuyev Andriy – PhD in Physical and mathematical sciences, Associate Professor, Head of the Interfaculty Department of General Educational Disciplines, Engineering Institute of Zaporizhzhya National University (226 Sobornyi Av., 69006 Zaporizhzhia, Ukraine).

Пожуєв Андрій Володимирович – кандидат фізико-математичних наук, доцент, завідувач Міжфакультетської кафедри загальноосвітніх дисциплін, Інженерний інститут Запорізького національного університету (просп. Соборний 226, м. Запоріжжя, 69006, Україна).

E-mail: scorpio6828@gmail.com

ORCID: <http://orcid.org/0000-0002-4083-5139>

Scopus Author ID: 6506407054