

Ivan Ihnat, Rudolf Jánoš

INDUSTRIAL DESIGN APPROACH TO SPECIFIC ENGINEERING DESIGN

Urgency of the research. Prior to industrialization, individuals undertaking design were artisan craftsman, one can speculate on what expertise and knowledge those active in design might need in a future post industrialist age. Currently, though, the activity of industrial design is generally linked to product development in a manufacturing context. Industrial Design is inextricably a part of innovation and it can make a contribution in the broad categories of innovation activity:

Target setting. Industrial design is only one sort of design. It has much in common with architecture and the various versions of design within engineering. Indeed the relationship between industrial design and mechanical and production engineering is similar to that enjoyed by architects with civil engineers.

Actual scientific researches and issues analysis. A design method is a normative scheme that specifies in detail a certain working procedure, the activities to perform, and also specifies order in which the activities should be carried out. It is usually very precise, and the designer is to follow it meticulously.

Uninvestigated parts of general matters defining. Most articles and other publications relating to problem of human-machine interaction, reduces this problem on ergonomic of controls and displays. In my article will be the ergonomic only one the constrains and I will not re-publish in my work anthropometric parameters, but I will put my effort on less common, but very important factors of industrial design in robotics.

The research objective. Concept originality means number of innovative features or technologies encompassed to robot concept. Score is for innovations could be in robot kinematic chain, drives, cabling, workspace, user interface, safety, etc.

The statement of basic materials. Engineering design has merit in continuous improvement of the basic parameters of the robot by applying newest outcomes of technology areas of mechanics, metallurgy, cybernetics to robot construction and control. Main objective of engineering design is to improve positioning accuracy, repeatability, load capacity, service life by the reduction of weight, energy demand, ecology impact and prices.

Conclusions. Design must be understood as a word that describes both a process and an outcome. It is the process of turning ideas into material things. Design cost is typically a very small portion of total product cost, but design process has major impact on product success.

Keywords: industrial design; Scara robot; engineering design.

Fig.: 12. **References:** 8.

Introduction. Industrial robots have enormous social-economic importance. Prices of industrial robots has felled significantly. In 2000, the price of industrial robots was around 1/5th of the price of robots in 1990. With the increasing number of robots proportionally increases the number of people who come into contact with robots. While in the past there were mainly experts who experimentally introduced the robots to production in large enterprises, today robotics has become a necessity in small and medium-sized enterprises, so now are robots administered by more “ordinary” engineers and workers who are not specialized directly in robotics. With the trend of massive deployment of robots in smaller enterprises became a need for adaptation of industrial robots to a wider group of users as it was before. Adaptation is mainly in level of interaction between robots and humans. Analogies maybe in personal computers. Their first generation was programmed and operated by team of highly specialized experts in the field of informatics, who cared about their software and electrical engineering team, who maintained the hardware. Programming took place at the level of machine code and maintenance consisted of exchange of elementary defective computer parts. However, few current computer users have an idea about the binary code or the functioning of one of the tens of millions of transistors in the processor. Instead, the computers are effectively used for daily work and a lot of users can replace computer’s hard drive by themselves. The logical evolution of industrial robots, with their decreasing price should be in intensive “humanization”, so that they could become common tool for achieving high efficiency and quality even in SMEs – enterprises where a decade ago was not possible to deploy a robot for personal and financial shortcomings. Situation when the industrial robot will be so common in SMEs such as the laser printer is coming. To achieve this, it is necessary to create a new generation of industrial robots based on the principles of consumer affairs – on the principles of industrial design [1, 3, 4].

Object of research. Object of design research is experimental prototype of SCARA robot solved in department of Robotics of Faculty of Mechanical Engineering of Technical University of Košice, fig. 1.

Concept of robot is based on Yamaha YK400 scara robot. From this template has dual-shaft configuration of z-axis and laid-out second arm. General layout of this robot follows most popular design of scara robots. Kinematic description was carried out in section “Scara robot decomposition” [5].

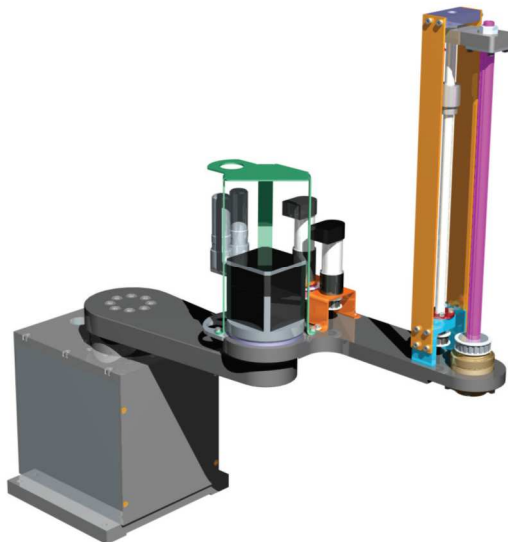

Fig. 1. New design of ballscrew shaft support

The robot is powered by harmonic drives FFA-32B-80-L-RES-B, FFA-20-80-L-RES-B on first and second axis with direct drive. Rotational and linear movement of vertical arm is powered by two additional drives via belt drive [3].

Pre-existing engineers' design. In time of my involvement into project many strategical decision about robot design were already decided and many parts were machined – see fig. 2. Both arms had final shape. Base of the robot had only temporary construction and originally proposed design was able to absorb the changes without financial and material drawback. Z-axis subassembly utilizes dual-shaft configuration. Ballscrew shaft must be lubricated and cannot stay outside the cover, but must be isolated from surrounding [6].



Fig. 2. Experimental SCARA robot

The project of experimental SCARA robot is solved by department that have access to variety of production machines, but no access to foundry, thus the parts cannot be molded, even if it will be very effective. Denso SCARA robots have most body parts molded to achieve specific shape, which cannot be produced by machining. In this project most part will be machined on CNC machines, including complex shaped from aluminum alloys and steel. Thin

TECHNICAL SCIENCES AND TECHNOLOGIES

wall complex shaped parts (mostly covers) can be laminated to machined forms, but not injected. Specific parts can be produced by rapid prototyping methods.

Laid-out arm. Concept of laid out second arm of engineering proposal was inspired with Yamaha YK400. Laid-out arm allows to downsize size it and reduce moment of inertia. Using this concept, it is not appropriate for each arm, and if is incorrectly used, can have the opposite effect – increasing the moment of inertia. Limit criterion for this concept should be at first place the shortage of space for a drives of the third and fourth axis between the drive of second axis and Z-axis. In this case is laid-out concept appropriate. Side effect of laid-out concept is increasing of the weight of the arm (green box on following figure) and thus its moment of inertia. The transfer of drives of third and fourth axis closer to the axis of rotation may not sufficiently compensate the increase of weight of arm and in this case is the use of laid-out concept disadvantageous. Unfortunately, this is the case of processed engineering design of scara robot [8].

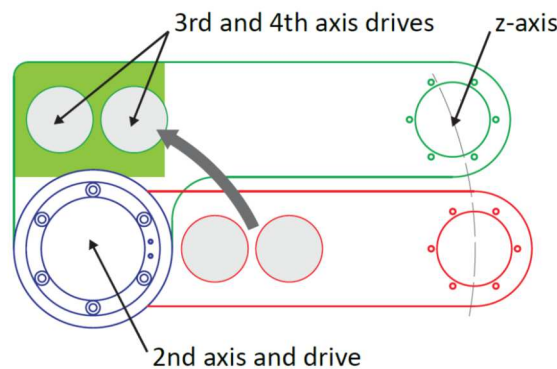

Fig. 3. Maximum gradeability of service robots

Instead of upper mentioned disadvantages, following design is build on laid-out second arm. The main reason for utilizing this concept is the state of the project and finished parts.

First draft proposal. First design of cover, fig.4 was proposed after my involvement to project of experimental SCARA robot. On this design I have defined volume of robot which need to be protected and covered. By designing of this first version I have identified first critical constrains of engineers' concept.

- Utilizing of laid-out second arm was disputed (see previous section).
- Second arm was too small for effective cover support.
- Z-axis subassembly is too wide at the top end for design that should express speed.

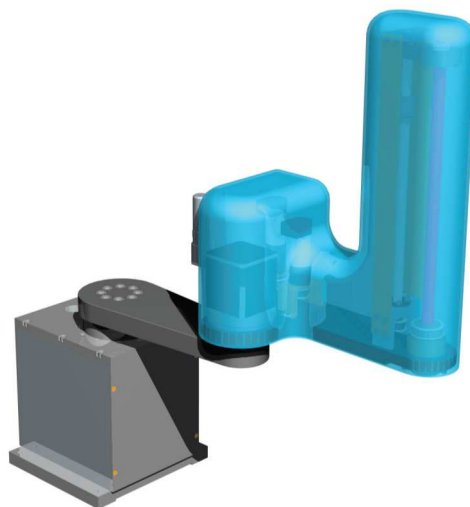

Fig. 4. First proposal of cover

Second proposal. This design was created for partial project evaluation. This concept deals with laminated covers of base and second arm. Design doesn't effects in any way the engineers' concept and only adds two part to existing parts. By designing of the shape was taken into account the technological process of laminating – releasing the laminated product from form and thus because all surfaces are slanted against the floor. One of the aims by styling of this design was to obtain smooth shapes of covers that will express speed of robot. On this concept I have confirmed that from box base will never be a smooth shape, nor if the edges are rounded, fig. 5 [7].

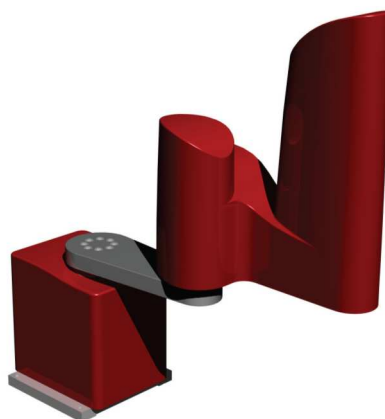

Fig. 5. First proposal of cover

Major changes to engineering design. First concept of robot carried out by robot engineers put ultimate constrains on final design. These constrains led to insufficient designs (first and second proposal) that did not satisfied me. After short research I have identified four major constrains of original design, fig. 6:



Fig. 6. Engineers proposal of base, support of ballscrew shaft and second axis drive

- Construction of base
- Support of ballscrew shaft
- Shape of second arm
- Orientation of second axis drive

Construction of base. Engineering team designed base from two L-profiled parts. Disadvantage of this proposal was in large floor space of robot. I have tried to minimize floor space by designing new robot base.

Base consists of three parts. Bottom plate with holes for bolts that fixing robot to the floor has diameter only 186 mm. Mounting bolts have spacing 146 mm (original have spacing 180 × 210 mm). Middle part is tube with diameter 180 mm and height 200 mm. This part has also holder of bottom part of cable and cut for motor cables. Top part is circle flange for drive.

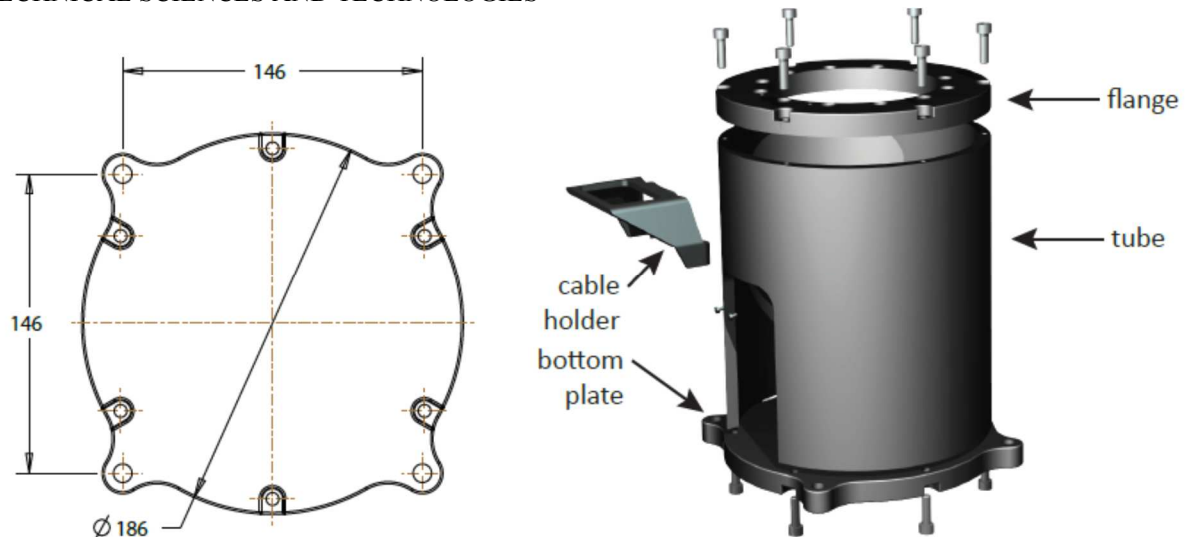

Fig. 7. Mounting plate and redesigned base

Support of ballscrew shaft. Support of ballscrew shaft in engineering concept was carried out by two parallel sheetmetal plates by sides of ballscrew shaft. Disadvantageous was the constant distance between these two sheetmetals that disabled to design effective cover. On the other hand parallel sheetmetals were not very rigid. In my concept I propose to support ballscrew shaft by rod for which is adopted existing base block of ballscrew shaft. This change brings reduce of wide of top part from 65 mm to only 30 mm, fig. 8.

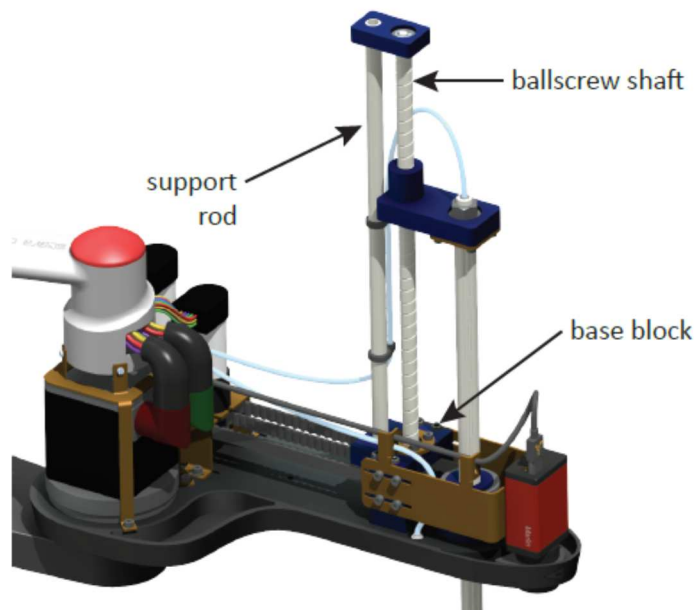

Fig. 8. New design of ballscrew shaft support

Shape of second arm. The shape of second arm of original design did not have enough space for holding the cover of arm. Unfortunately this arm is already machined, thus I have designed a thin frame around the arm to support the cover of arm. Frame increases the original arm for 4 mm on sides. This frame also covers the camera in front of z-axis and outgoing cables from second axis drive, which was rotated to fill cut in the arms as is described in following section, fig. 9.

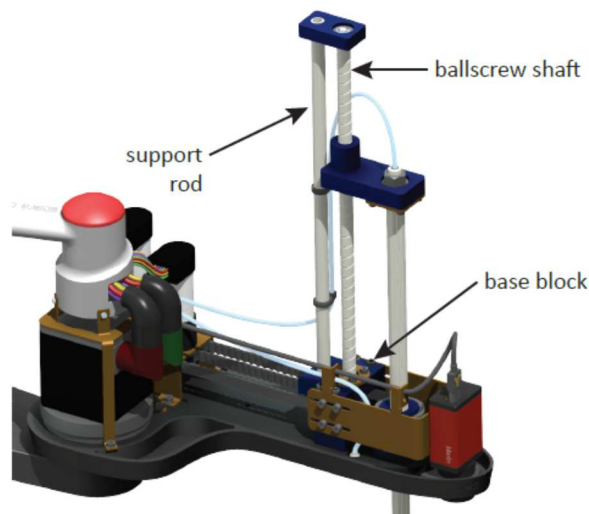

Fig. 9. New design of ballscrew shaft support

Orientation of second axis drive. In original design the second axis drive was oriented with wire terminal pointing to base. Cables in that design were overlapping the robot's arm that put requirement on additional volume of cover of arm. In final design the drive is rotated about 180° around the joint to point the cables to z-axis direction. This orientation fills the cut in the arm caused by laid-out concept and makes the arm visually more compact, fig. 10.

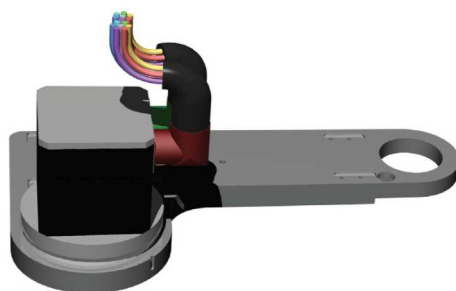

Fig. 10. Orientation of second axis drive

Integrated vision system. As was mentioned in analytical part of dissertation thesis most of the scara robot application requires vision system. In this concept is the camera located at the end of second arm in front of z-axis. This position is used in most current application, where is required to place lens at most closer position to z-axis. This design can hold up to medium size CCD or CMOS camera and standard lens. Camera is flexible attached to arm by sheetmetal camera holder. Holder can be positioned in front-back and up-down direction, fig. 11.

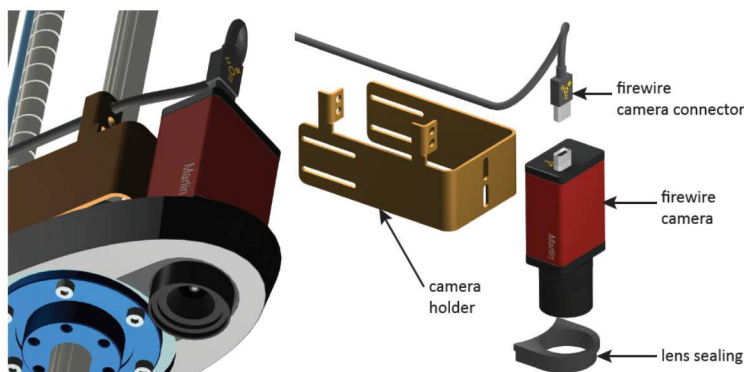

Fig. 11. Orientation of second axis drive

TECHNICAL SCIENCES AND TECHNOLOGIES

Final design. Final design of robot, fig. 12 was proposed with respect to all defined requirements and constraints. Original concept of base and body was changed to meet overall design concept. At first place was the integration of breakthrough features like internal camera, fast-clipping covers and solid cable that can put the users' experience on higher level. Styling of this concept has effort to attract wide range of users and potential users, so at second place was to introduce original color and shape styling. Black painted visible metal parts are combined with two color covers, where light grey surfaces are combined with aggressive red. Shape of the covers hides all cables including main terminal and its connectors, which is visible only from back side. Shape of top cover part can evoke the shape of wing of air fighter, which expresses speed and power. All these features and stylings must meet ergonomic and safety criteria [2].

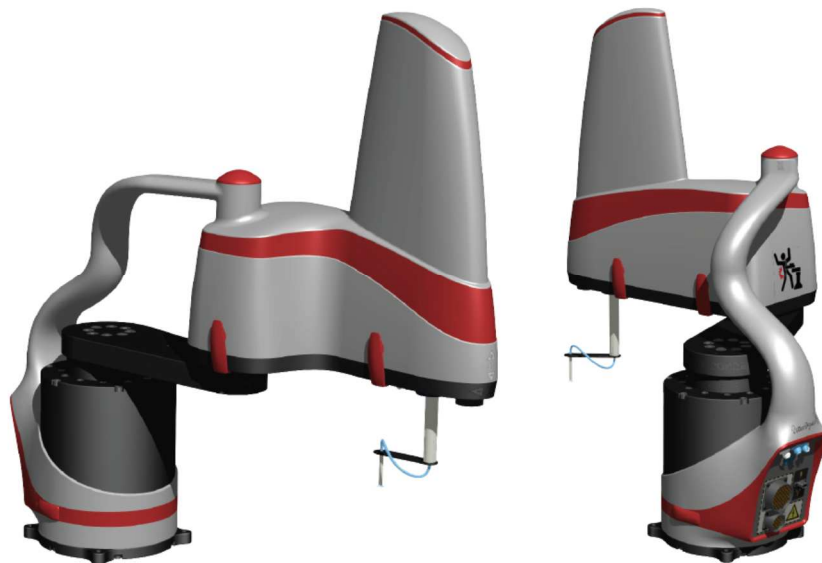

Fig. 12. Final design

Conclusions. Basing the analysis and the experience from process of designing the existing concept, can be concluded following:

- Industrial design is an integral part of product design including the robots.
- All products must be designed in respect to human criteria, including those where user contact is not common from a first point of view.
- Styling, shape form, color and other factors have their own rules and thus must be designed by a persons with appropriate knowledge – mostly industrial designers.
- Industrial designers must be involved at very first beginning of design proposal; later involvement can do both – raise the expenses and lead to design deficiency.

By utilizing previous statements was developed virtual 3D CAD model. This model of industrial design after reviewing by engineering team will be used for finishing the construction of existing experimental SCARA robot.

Acknowledgement. This work has been supported by the Slovak Grant VEGA 1/0389/18 Research on kinematically redundant mechanisms

References

1. Aguilar, S.: Playing it safe with robotic welding, Practical Welding Today, 2004.
2. Akao, Y.: Quality Function Deployment: Integrating Customer Requirements into Product Design, Productivity Press 2004 ISBN: 1-56327-313-6.
3. Bogdanovič, L. B. – Burjan, V. A. – Rautman, F. I.: Design v strojárstve. Alfa, Bratislava, 1981.
4. Ramos, D. C., Moreno, U. F., & Almeida, L. (2016). Method for design and performance evaluation of ad hoc networked mobile robotic systems using, PapersOnLine, 49(30), 144-149.
5. Eco, U.: A theory of semiotics, Indiana University Press, 1979, ISBN 02-532-0217-5.

6. Hjelm, S. I.: Semiotics in product design, Centre for user oriented design 2002.
7. Jones, C. J.: Design Methods, John Wiley and Sons 1992, ISBN: 04-712-8496-3.
8. Krippendorff, K.: The Semantic Turn: A New Foundation for Design, CRC Press 2006, ISBN: 0-203-299995-7.

УДК 621.865.8

Іван Ігнат, Рудольф Янош

НАБЛИЖЕННЯ ПРОМИСЛОВОГО ДИЗАЙНУ ДО СПЕЦИФІКИ ІНЖЕНЕРНОГО ПРОЕКТУВАННЯ

Актуальність теми дослідження. До індустріалізації люди, які займалися дизайном, були майстрами-ремісниками, ы можна тільки припустити, який досвід та знання можуть знадобитися тим, хто займається дизайном у майбутню постіндустріальну епоху. Однак, в даний час діяльність в галузі промислового дизайну, як правило, пов'язана з розробкою продукції у контексті виробництва. Промисловий дизайн є невід'ємною частиною інновацій, і він може зробити свій внесок у різні категорії інноваційної діяльності

Постановка проблеми. Промисловий дизайн - це лише один вид дизайну. Він має багато спільного з архітектурою та різними версіями дизайну в рамках інженерних робіт. Насправді взаємозв'язок між промисловим дизайном та машинобудуванням і промисловим виробництвом аналогічний тому, яким користуються архітектори з цивільними інженерами.

Аналіз останніх досліджень і публікацій. Метод проектування - це нормативна схема, яка детально описує певну робочу процедуру, виконувани дії, а також визначає порядок, в якому ці дії повинні здійснюватися. Зазвичай це дуже точно, і проектувальник повинен ретельно стежити за цим.

Виділення недосліджених частин загальної проблеми. Більшість статей та інших публікацій, що стосуються проблеми взаємодії людина-машина, фокусуються на проблемі ергономічності елементів управління та дисплеїв. У моїй статті будуть лише ергономічні обмеження і не будуть повторно публікуватися антропометричні параметри, але будуть спрямовані зусилля на менш поширені, проте дуже важливі аспекти промислового дизайну в робототехніці.

Постановка завдання. Оригінальність концепції означає низку інноваційних функцій або технологій, що охоплюють концепцією робота. Цінність іновацій може мати місце у кінематичному ланцюзі робота, приводах, кабелях, робочій області, інтерфейсі користувача, безпеці тощо.

Виклад основного матеріалу. Інженерне проектування має перевагу в постійному вдосконаленні основних параметрів робота шляхом застосування новітніх досягнень технологічних областей механіки, металургії, кібернетики для конструювання та управління роботом. Основна мета інженерного проектування - підвищити точність позиціонування, повторюваність, вантажопідйомність, термін служби за рахунок зменшення ваги, енергоспоживання, впливу на навколишнє середовище та ціни.

Висновки відповідно до статті. Під проектуванням слід розуміти слово, яке описує як процес, так і результат. Це процес перетворення ідей у матеріальні речі. Витрати на проектування, як правило, становлять дуже невелику частину загальної вартості виробу, але процес проектування має значний вплив на якість виробу.

Ключові слова: промисловий дизайн; робот Scara; інженерне проектування.

Рис.: 12. Бібл.: 8.

Ihnáth Ivan – Doctor of Technical Sciences, Technical University of Kosice, Faculty of Mechanical Engineering, Department of Robotics (Park Komenskeho 8, 04200 Kosice, Slovak Republic).

Ігнат Іван – доктор технічних наук, Технічний університет Кошице, Механічний факультет, кафедра робототехніки (Park Komenskeho 8, 04200 Kosice, Slovak Republic).

E-mail: ivan.ihnath@tuke.sk

Jánoš Rudolf – Doctor of Technical Sciences, Associate Professor, Technical University of Kosice, Faculty of Mechanical Engineering, Department of Robotics (Park Komenskeho 8, 04200 Kosice, Slovak Republic).

Рудольф Янош – доктор технічних наук, доцент, Технічний університет Кошице, Механічний факультет, кафедра робототехніки (Park Komenskeho 8, 04200 Kosice, Slovak Republic).

E-mail: rudolf.janos@tuke.sk

Scopus Author ID: 55016528600