

Róbert Rákay

**WIRELESS SERVOMOTOR CONTROL FOR REMOTE ACTUATION**

**Urgency of the research.** Actual trends of home and hobby automation focus on implementation solutions to everyday life situations. The main goal is usually to simplify or remotely control a task with low cost devices.

**Target setting.** When designing automation systems of different devices, developers are trying to find the most reliable and effective solution with fulfilling every base requirement.

**Actual scientific researches and issues analysis.** To prepare this paper, different publicly available datasheets and experimental solutions were analyzed as well as conclusions of our previous and other ongoing experiments were used to create the knowledge base about this topic.

**Uninvestigated parts of general matters defining.** There are many different communication solutions and every manufacturer of communication device provides its own solution. This paper is insufficient to describe them all. But creates base for further result comparison with other future solutions of the same task. The proposed solution is not connected to any moving object. In a real application the requirements of torque and system power consumption has to be considered.

**The research objective.** In this article a model of a remote control system is proposed for a home automation, in this article a wireless connection is created to remotely control position of servomotor.

**The statement of basic materials.** To propose a future model of home appliance control system it is necessary to implement the newest communication technologies. Using the new communication protocols such BLE, LoRA or nRF provides good basis to solve this issue.

**Conclusions.** The proposed paper introduces a model wireless remote control system for simple tasks such controlling of lights or dimmers. The tested system provides a good basis for future real life application, however, it needs to be adapted to specific tasks.

**Keywords:** wireless control; home automation; servomotor.

**Fig.:** 6. **Table:** 2. **References:** 8.

**Introduction.** The main task of remote control systems is to operate another devices from a distance. In the past these systems were realized as wired low range teleoperation systems. In current solutions this kind of remote operation is applied only for very hazardous task such as radioactive or explosive environments. The wired systems are replaced with wireless communication and nowadays automated systems are aimed to make everyday life easier and more comfortable for every person in society. This can be reached by creating of different automated microsystems which can replace or help with tasks such as appliance control or opening and closing of objects controlled by electrical devices. [1]

Not every automation task requires connection via Internet and people with temporary or permanent disabilities can use local wirelessly controlled devices. This type of remote control system can be built using wireless communication protocols as:

- Bluetooth, BLE
- ESPNow
- LoRA
- ESPNow
- Other RF based protocols.

Each of these communication tools share the form low to medium range, lower transfer rates and connection limitations. Despite the limitations of the above mentioned protocols, they can be integrated to control lights, blinds and other simple devices. The transferred data doesn't contain any private information and in most of cases they are not time critical too [2-4].

By integrating of electrical actuators we can carry out different functions. For example a servo motor can replace the activity such as door or hatch opening and closing.

Minimal requirement to determine applicability of servo motor is to determine the torque. The torque is a force applied at a right angle to a lever multiplied by its distance from the lever's fulcrum (the length of the lever arm). It means that if we want to lift a 2 kg object, and the lever arm is 2 cm long, we need a 0,4 N·m torque. The SI unit for torque is N·m or kg·m<sup>2</sup>·s<sup>-2</sup>.

For the purpose of an experimental system testing there is no exact task to be controlled remotely, and the devices are tested only as laboratory example. The main goal is to control the position of the servomotor.

The proposed control system consists of a transmitter device and receiver device, which are networked via the nRF24 modules. The input of the system is a potentiometer of 10kOhm, which is directly connected to the analog input of the microcontroller. This voltage value is read and processed to a digital value by the 10-bit ADC integrated to the Arduino. The processed value is then sent to the receiver of the system. The receiver controller has an attached servomotor connected to one of its digital outputs.

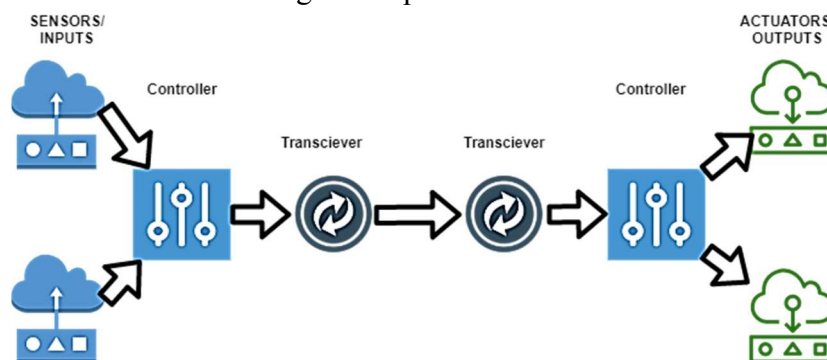

Fig. 1. Proposed remote control system

**nRF24L01 RF module.** This device works as transceiver modules, so each module can send and receive data. The transmission is half-duplex, they can either send or receive data at a time. These modules operate at a frequency of 2.4 GHz (Industrial Science Medical ISM band) with a transfer rate from 250 kbps to 2 Mbps, which is legal in many countries and can be used in industrial and medical applications. With suitable antennas, they can transmit and receive information up to 100 meters between them [5, 6].

The modules work with power supply of 1.9 to 3.6 V and have a consumption of 12mA during a normal operation. This makes the devices very battery friendly for remote system. The module communicates with the controller via SPI protocol.

Most of the module pins are 5V tolerant and can be easily interfaced with the Arduino like microcontrollers. Each module can communicate through 6 “Pipelines”, which means each module can communicate with 6 other modules to transmit or receive data. This makes the module suitable for star and mesh networks of IoT systems.

The module has to be configured within the control program of the connected microcontroller. There are available configurations defining the transfer speed, communication channel, power amplification, message size.

In our case the address was chosen 0, while the communication channel is 115 out of the available 125. The speed can variate from 250 kbps to 2Mbps. The power levels for the radio amplifier are adjustable to MIN, HIGH or MAX. For the maximum range the MAX is recommended but this creates an increased current consumption, so in case of battery powered systems this have to be considered while calculating the battery life.

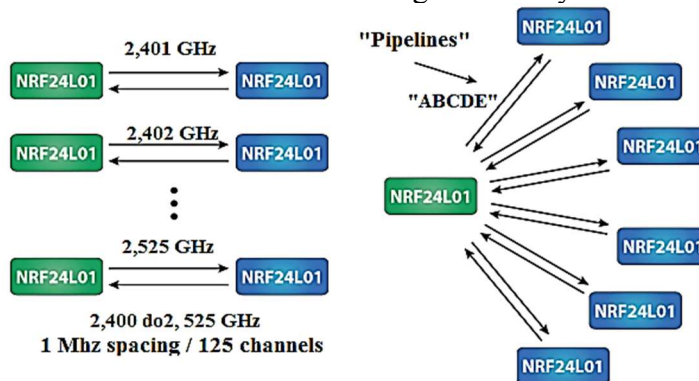

Fig. 2. nRF24L01 Pipelines communication principle

TECHNICAL SCIENCES AND TECHNOLOGIES

**Arduino UNO R3.** Arduino Uno is a microprocessor board based on ATmega328P. It has 14 digital I / O pins (6 of which can be used as PWM outputs), 6 analog inputs, USB connection, power connector, ICSP header and reset button. It can easily be connected to a computer using a USB cable powered by an AC adapter or a battery [7].

Table 1

*Technical details of ARDUINO UNO REV3*

Microcontroller	ATmega328P
Operating voltage	5V
Input voltage (recommended)	7-12V
Maximum input voltage	6-20V
Number of digital inputs / outputs	14 (6PWM)
Analog inputs	6
Maximum current for Vs / Res	20 mA
Maximum current for 3.3 V input	50 mA
Flash memory	32 KB
SRAM	2 KB
EEPROM	1 KB
Operation cycle	16 MHz
Dimensions (Length x Width)	68.6 x 53.4 mm
weight	25 g

To power the pins:

- Vin - input voltage for powering the board or powering peripherals.
- 5 V output pin for peripherals.
- 3V3 - reduced power supply.
- GND grounding pin.
- IOREF - reference voltage pin.

UART TTL (5V) serial communication is available to communicate with other devices. It uses RX and TX pins. In addition to UART, I2C or SPI communication can be used.

For communication with the computer it is possible to use the so-called serial monitor. Using it, we can transfer data to a PC.

**Microservo.** As an example output device the MG90S micro servo motor is used. This servo is suitable for task of remote control such as RC models. The movement of the servo is limited to 180°, or 90° in each direction. The technical characteristic of MG90S is described in the table below [8].

Table 2

*Technical details MG90S*

Weight	<b>13.4 g</b>
Operating voltage	4.8-6 V
Current	10 -250 mA (stall 700mA)
Torque (4.8 V)	0.1765197 Nm
Torque (6 V)	0.2157463 Nm
Operating speed (4.8 V)	0.1 s/60 °
Operating speed (6 V)	0.08 s/60 °
Dead band width	5 μs

**Software.** For programming and configuring the remote control system the Arduino IDE programming environment was used. It is a Java application, created to program different microcontrollers of Arduino and its clones. The main software includes the code editor, compiler, uploader and also tools for serial port monitoring. Every created control software includes the following parts:

- Declaration of variables, used libraries
- Configurations of I/O devices and communication
- Control loop, which will be conducted cyclically.

Figure below shows the programming environment Arduino IDE.

The control software is described with control algorithms below. The control software starts with the declaration of used libraries, which integrates functionalities to work with the connected peripherals as the communication modules and the servomotor. After the needed libraries the variables of the control program are declared. These variables include voltage value from the potentiometer, control value for servo position, communication variables. The next step is to configure the used communication channels and pins on the microcontroller. Finally, the main part of the control software is created, which is cyclically repeated.

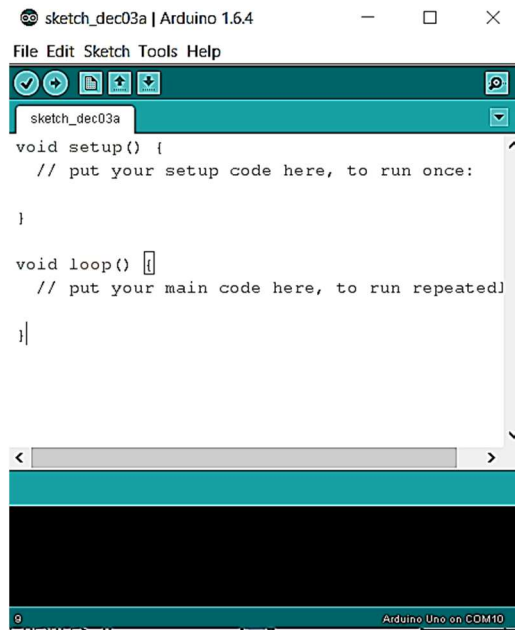

Fig. 3. Arduino IDE

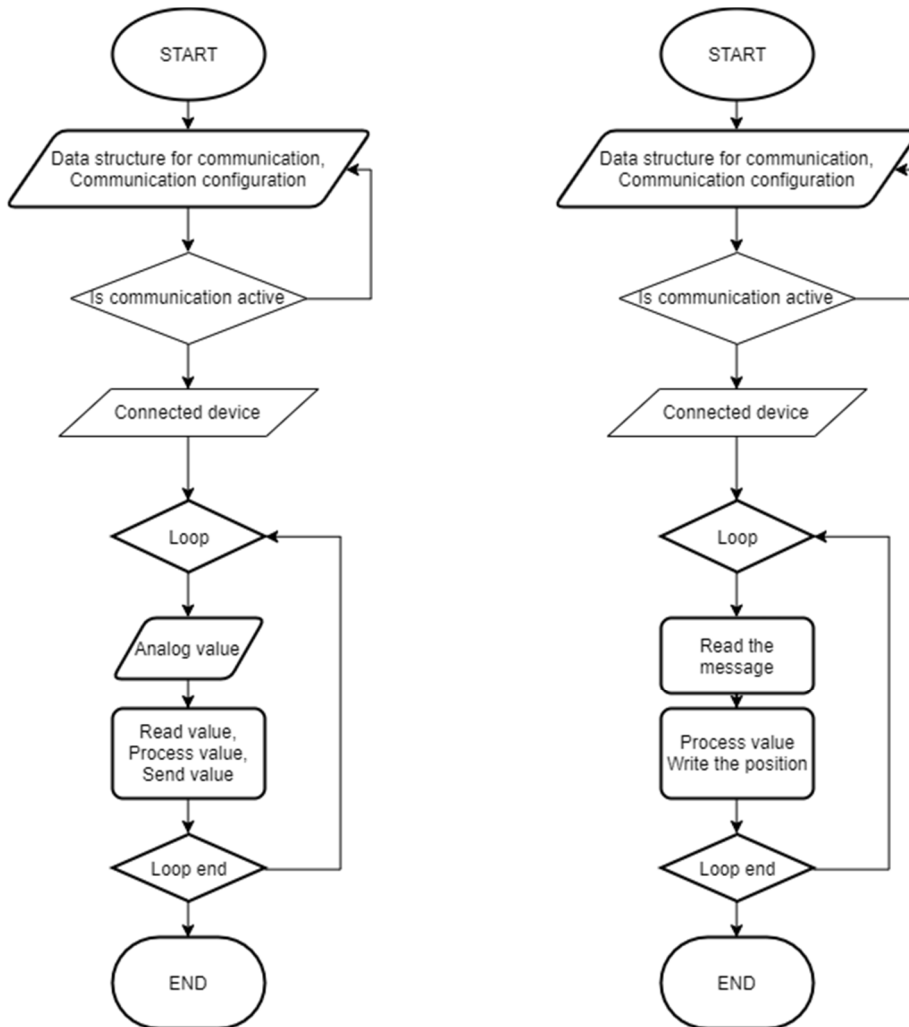

Fig. 4. Control diagram – sender and receiver programs

TECHNICAL SCIENCES AND TECHNOLOGIES

**Proposed system.** The proposed system was tested in laboratory environment. The picture below shows the proposed connection of both sides and the physical realization of such connections. The main microcontrollers are Arduino UNO Rev3. For experiments the USB Power supply cables were used. Also, for programming and monitoring of this system, the serial monitor functionality of the Arduino IDE was used.

The communication between the PC and the microcontrollers is configured to 9600 bit/s. The RF communication proceeded on channel n. 115. The speed of the wireless data transfer was 250 Kbps. The power amplifier was chosen to be LOW because of the short distance between the communicating partners. The final wiring of the system is shown on the next figures.

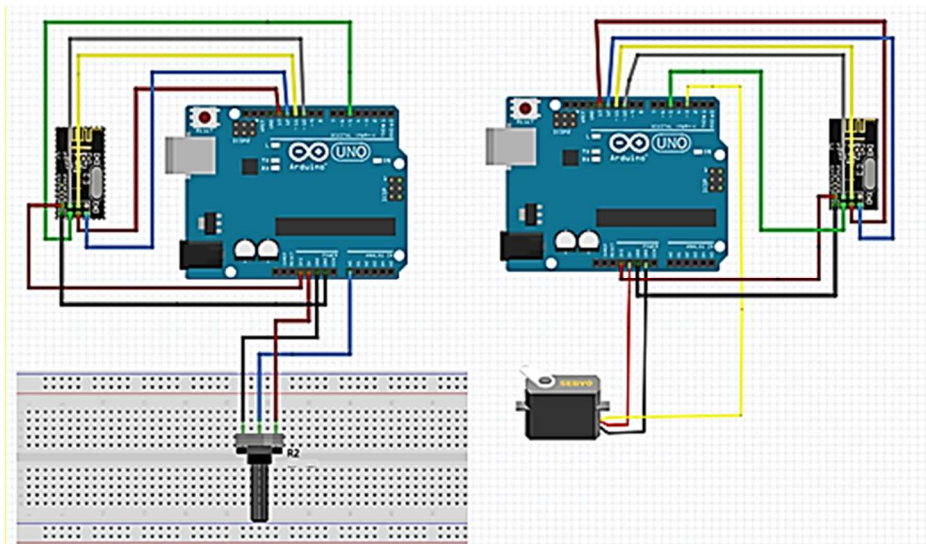

Fig. 5. Wiring schemes – sender and receiver

The experimental testing was successful. The picture below shows part of the control software with a detail of the received messages.

```

receiver
/*CE - 7
MISO - 12
MOSI - 11
SCK - 13
CS - 8
Recently tested with nano
*/

#include <SPI.h>
#include "RF24.h"
#include <Servo.h>

Servo myservo;

RF24 myRadio (5, 10);

struct package
{
  int msg;
};
typedef struct package Package;
Package data;

byte addresses[][6] = {"0"};

void setup()
{
  Serial.begin(9600);
  myRadio.begin();
  myRadio.setChannel(115); //115 band above WIFI signals
    
```



Fig. 6. Wiring schemes – sender and receiver

**Conclusion.** In this paper, a proposal of model remote-control system is described. To fulfill a real-life task requirement, it's necessary to replace the servo motor to be able to manipulate with an object, also the power consumption has to be analyzed. In this case a model system can only represent the means of describing functioning not a concrete device for a

specific application. The communication protocol nRF is lightweight transfer technology working in the range of standardized ISM band. With its characteristic it's well suitable for simple home automation systems, where one or more physical tasks are replaced with electrical devices. As a controlled device a servomotor is implemented on the receiver side. The position of the servomotor is determined by the received messages from the sender side. The input value of the system is created with a potentiometer and analog to digital conversion.

The carried-out experiment showed that to automate tasks as an appliance control (lighting and dimmer devices) a remotely controlled actuator is suitable solution. This type of automated system can help to older people and people with disabilities to make their everyday life easier or comfortable or more independent. By combining batteries with these systems, we can create simple powerful micro automated systems. Compared to commercially available systems the proposed solution offer advantages as reconfigurability with different peripheral devices, reusability in various tasks and provides good basis of knowledge in the education of students of automation and mechatronics.

**Acknowledgement.** This work has been supported by the Slovak Grant VEGA 1/0330/19 - Výskum a návrh algoritmov a systémov pre fúziu rôznorodých dát v multisenzorových architektúrach and H2020: Manufacturing Industry Digital Innovation Hubs (MIDIH), reference no. 767498.

### References

1. KETSHABETSWE, Lucia Keleadile, et al. Communication protocols for wireless sensor networks: A survey and comparison. *Heliyon*, 2019, 5.5: e01591. Available from: <https://www.sciencedirect.com/science/article/pii/S2405844018340192?via%3Dihub>.
2. KAR, Udit Narayana; SANYAL, Debarshi Kumar. An overview of device-to-device communication in cellular networks. *ICT express*, 2017. Available from: <https://www.sciencedirect.com/science/article/pii/S2405959517301467>.
3. ŠIMŠÍK, D. - GALAJDOVÁ, A. - ŠEMINSKÝ, J. - RÁKAY, R. - VIŠŇOVSKÝ, M. Inovácia študijného programu automatizácia a riadenie strojov a procesov v reakcii na požiadavky priemyselnej praxe, ARaP 2016. - Praha: MM publishing, 2016 pp. 79-82. - ISBN 978-80-906310-1-4.
4. ŠEMINSKÝ, J. - Near future manufacturing systems - present and future In: Interdisciplinarity in Theory and Practice. No. 8 (2015), p. 282-284. - ISSN 2344-2409 [online], Available from: <https://docs.google.com/viewerng/viewer?url=http://itpb.eu/pdf/2015-4/8cislo52clanok.pdf&wmode=transparent>.
5. nRF24L01 Datasheet [online], Available from: [https://www.sparkfun.com/datasheets/Components/nRF24L01\\_prelim\\_prod\\_spec\\_1\\_2.pdf](https://www.sparkfun.com/datasheets/Components/nRF24L01_prelim_prod_spec_1_2.pdf).
6. nRF24L01 Datasheet [online], Available from: <https://www.electronics-lab.com/project/communication-between-two-arduinios-using-nrf24l01>.
7. Arduino UNO REV 3 Datasheet [online], Available from: <https://store.arduino.cc/arduino-uno-rev3><https://store.arduino.cc/arduino-uno-rev3>.
8. MG90S Datasheet [online], Available from: <https://protosupplies.com/product/servo-motor-micro-mg90s>.

УДК 62-529:681.5

*Ракай Роберт*

## БЕЗПРОВІДНИЙ КОНТРОЛЬ СЕРВОМОТОРА ДЛЯ ДИСТАНЦІЙНОГО УПРАВЛІННЯ

**Актуальність теми дослідження.** Актуальні тенденції автоматизації дому та хобі зосереджуються на впровадженні простих рішень у повсякденні життєві ситуації. Основна мета - це, як правило, спростити або віддалено керувати завданням із недорогими пристроями.

**Постановка проблеми.** Розробляючи системи автоматизації різних пристроїв, розробники намагаються знайти найпростіше рішення з виконанням кожної базової вимоги.

## TECHNICAL SCIENCES AND TECHNOLOGIES

**Аналіз останніх досліджень і публікацій.** Для підготовки даної роботи були проаналізовані різні загальнодоступні таблиці даних та експериментальні рішення, а також були зроблені висновки наших попередніх та інших постійних експериментів для створення бази знань з цієї теми.

**Виділення не досліджених частин загальної проблеми.** Існує багато різних комунікаційних рішень, і кожен виробник пристрою зв'язку пропонує своє рішення. Ця стаття є недостатньою для їх опису. Але створює базу для подальшого порівняння результатів з іншими майбутніми рішеннями тієї ж задачі.

**Постановка завдання.** У цій статті пропонується система дистанційного керування для домашньої автоматизації, у цій статті створено бездротове з'єднання для дистанційного керування положенням сервомотора.

**Виклад основного матеріалу.** Щоб запропонувати майбутню модель системи управління побутовими приладами, необхідно впровадити новітні комунікаційні технології. Використання нових протоколів зв'язку, таких як BLE, LoRA або nRF, дає хорошу основу для вирішення цього питання.

**Висновки відповідно до статті.** У запропонованій статті представлена бездротова система дистанційного керування для простих завдань, таких як управління фарами або диммерами. Тестована система забезпечує хорошу основу для майбутнього застосування в реальному житті.

**Ключові слова:** безпроводний контроль; домашня автоматизація; сервомотор.

Рис.: 6. Табл.: 2. Бібл.: 8.

**Róbert Rákay** – Assistant Professor, Technical University of Kosice (Letná 9, 04200, Košice, Slovak Republic).

**Ракай Роберт** – доцент, Технічний університет Кошице (Letná 9, 04200 Košice, Slovak Republic).

**E-mail:** robert.rakay@tuke.sk

**ORCID:** <https://orcid.org/0000-0002-7151-3749>

**Scopus Author ID:** 56922070700