

UDC 620.17

DOI: 10.25140/2411-5363-2020-3(21)-249-258

Patrik Šarga, Martin Studený

POSSIBILITIES OF STRESS MEASUREMENT IN STRUCTURES USING MODERN TECHNOLOGIES

Urgency of the research. In many industrial areas, knowledge of deformation stresses in materials is required. Mainly for safety, continuous monitoring of the condition, the maintenance planning, overall prediction of the service life of structures, as well as for other reasons aimed at saving money and time required for repairs.

Target setting. The research aimed to create a "low-cost" monitoring device for monitoring the stresses in the structure, created on the principle of IoT.

Actual scientific researches and issues analysis. When designing the system and preparing this paper, we considered both current sources – publications and papers dealing with the current state of development of the monitoring IoT systems as well as existing solutions, which are available on the market.

Uninvestigated parts of general matters defining. The mobile application was not implemented at this stage. It will be implemented in the next stage of development.

The research objective. The purpose of this article is to explain how we can create own IoT monitoring system by using Arduino platform.

The statement of basic materials. In our work were used components from Arduino, which is the world's leading open-source hardware and software ecosystem. The company offers a range of software tools, hardware platforms and documentation enabling almost anybody to be creative with technology.

Conclusions. The created IoT monitoring device was created on the Arduino platform. The software part was implemented in the Arduino IoT Cloud environment. Testing of the device has proven its functionality during the practical deployment of the created system. It is possible to modify it to best suit the specified requirements.

Keywords: Arduino; Raspberry Pi (RPI) Internet of things (IoT); strain gauges; Arduino IoT Cloud.

Fig.: 13. References: 16.

Introduction. Monitoring of deformation stresses is an important part not only of industrial production but also of many other sectors. It is essential to know the stress of structures in terms of preventing possible failures, predicting the residual life of the material, etc. [1; 2].

Our goal is to create a device for monitoring stresses in the structure by the strain gauge method. Such a solution would be suitable for long-term monitoring of the condition of the structure (bridges, cranes, and others). The proposed solution is based on the IoT principle. The device should be single-purpose, i.e. it should detect the deformation on the selected structure, which is then converted to stress (bending, compressive or other). At the same time, it should be inexpensive, with low consumption and must allow remote monitoring of the current state of the monitored structure. The Arduino platform is sufficient for this task. We decided to use a board from the Arduino MKR 1000 family. The choice of a specific type depends on the communication interface on which we want to implement data collection (Wi-Fi, Sigfox, LoRaWAN, GSM module or other). We chose the MKR 1010 board, which contains a Wi-Fi module [3].

Professional solutions from HBM. Commercially available systems for measuring stresses in a structure using strain gauge measurement have their negatives. Conventional devices used so far are not suitable for remote monitoring of stresses in the structure. The next generation of measuring systems meets this requirement, but the problem is the high price. That is why we were looking for our own, reliable and affordable solution.

Currently, there are several types of professional measuring devices in the world from various manufacturers for strain gauge measurements of mechanical quantities. We will focus on equipment from HBM company, which is a leader in the field of measurement technology and has a comprehensive portfolio of products needed for the implementation of strain gauges (sensors, apparatus, software, and others).

Quantum X is a universal, accurate and reliable system for measuring various physical quantities. It is compatible with HBM sensors and Catman software and provides a comprehensive solution for measuring and testing structures. Quantum X family measuring devices are also designed for standard local strain gauge measurements, and some models also allow synchronization via FireWire or Ethernet, as shown in the Quantum X modular concept (Fig. 1) [4].

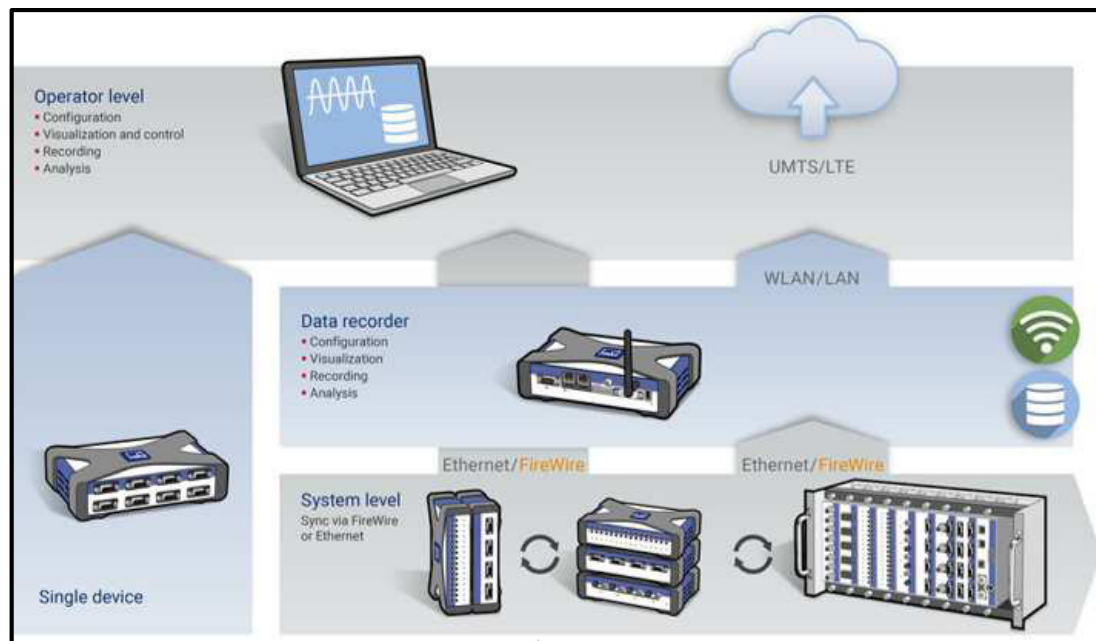

Fig. 1. Quantum X [4]

Such a solution allows us to a certain level of remote monitoring of measured data, but it is not built for cloud monitoring.

Another option is the PMX device from HBM (Fig. 2), which is also an accurate, reliable and efficient measuring device. It is a multi-channel system that is designed for the collection and processing of large amounts of data. It is equipped with interfaces (Profinet, EtherCAT, Ethernet IP, TCP/IP) [5].



Fig. 2. PMX [5]

The PMX can be flexibly expanded with practical plug-in cards for different types of measurements to suit specific needs. Technical data on expansion plug-in cards are given in the source [5]. It is also possible to configure PMX and monitor the required quantities using the web interface (Fig. 3). Such a solution already meets the requirement of IoT, but the main disadvantage of this system is its high price [5].



Fig. 3. Web interface of PMX [5]

Solutions from Embedded Micro Technology. In the next section, we will introduce commercial solutions based on the low-cost platforms Arduino and Raspberry Pi.

Raspberry Pi development boards are often seen only as platforms for the agile development of prototypes of electronic devices for educational and experimental purposes. Possibilities of their usage in the industrial environment are often underestimated, or they are used only in the field of development. However, this practice is gradually changing, and some companies have launched industrial versions of Raspberry Pi development boards. The flexibility of their programming and their easy adaptation to existing installations can bring several benefits to industries. They can be used either as low-cost alternatives to traditional industrial automation and control systems or to extend the functions of older industrial systems, e.g. the possibility of remote monitoring. Among the companies that offer devices based on RPi is the company Embedded Micro Technology, which develops industrial integrated boards "MyPi" usable also for IoT [6].

The MyPi (Industrial IoT Integrator Board) (Fig. 4) is specially designed for the industrial market, providing a powerful and easy-to-use platform. It contains a CPU based on the RPi computing module with broad OS support and easy integration into the cloud services of the Internet of Things. The integrated platform has an IO interface and several built-in cards for standard network protocols such as e.g. (Modbus, CAN, RS485 and many more) [6].

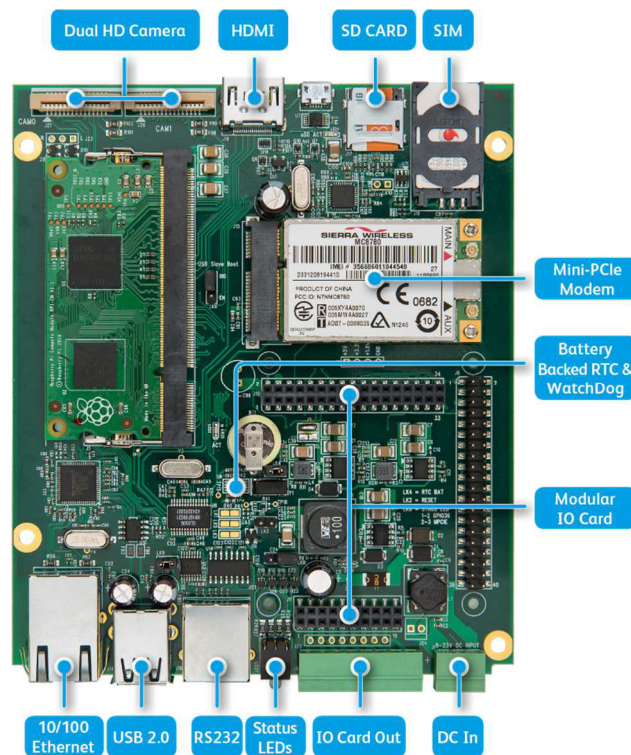

Fig. 4. Industrial IoT Integrator Board (MyPi) [6]

Solutions by Industrial Shields. Another possible solution is offered by the company Industrial Shields, which focuses on the construction of PLCs based on the Arduino platform, but also RPi.

PLCs created on the Arduino platform offer solutions based on Arduino Leonardo or Arduino Mega boards (Fig. 5). The choice of board used depends on the requirements of the system. There are several communication interfaces to choose from (Wi-Fi, GPRS, LoRa, DALI), protocol support (RS485, RS232, SPI, I2C, Modbus RTU). It is also possible to choose a solution that will contain multiple, up to 20 I/O (digital, analogue, relay). [7]



Fig. 5. PLC based on Arduino [7]

A more robust solution from Industrial Shields is based on the RPi board (Fig. 6). Compared to Arduino, it offers higher performance, multiprocessing, a Linux based operating system, multiple connectivities. Thanks to the dual Ethernet ports, the dual RS-485, Wi-Fi, Bluetooth, CAN bus and other options, it is possible to connect to a large number of devices and to use multiple protocols and communication ports. These parameters also result in higher energy consumption, which is still lower compared to the PMX system from HBM.

The standard programming environment Arduino IDE, Python, Node-RED and similar can be used to program these PLCs.



Fig. 6. PLC based on RPi [7]

Our solution. Since our goal was to create a monitoring system at the lowest possible price without the need for high performance, the choice was to create the original system, built on the Arduino platform.

Arduino boards contain a built-in processor, built-in RAM, without the possibility of expansion. They are designed for repetitive tasks (e.g. monitoring soil moisture, opening and closing garage doors, controlling lighting, controlling small devices such as sensors, motors, lights, and others). They are suitable for tasks that do not require a large amount of memory and such a powerful processor.

Arduino boards' main advantage is that they can be in continuous operation, as energy from an external source, such as a power bank, is sufficient for their operation. That allows them to be used out of reach of the mains. Arduino boards are built on an open-source platform. The Arduino platform offers several types of development boards with different features as well as large expansion add-on boards [8].

Because our goal was to create an IoT solution, we have chosen an Arduino board from the MKR 1000 family, which also has a built-in communication protocol. Since we wanted to use the Wi-Fi interface, we chose the MKR WiFi 1010 version [9].

The Arduino MKR 1010 (Fig. 7) is a compact and powerful board based on the Atmel ATSAMW25 SoC (System on Chip) chip, which is part of the "Smart Connect family of Atmel Wireless devices" specially designed for IoT solutions. It includes a reliable 32-bit Arm Cortex-M0+ computing processor, a wide range of I/O interfaces and low-energy Wi-Fi technology with an encryption function for secure communication. The construction of the board further consists of a Li-Po charging circuit, which can work on an external 5V battery or by powering directly via the micro USB port on the board. Unlike other boards, it can operate with a minimum supply voltage of 3.3V, and its output pins continue to give an output voltage of 5V. It can detect the change of power supply automatically [9].

Arduino MKR 1010 board can be programmed either using the official Arduino IDE software or directly on Internet platforms providing a programming environment, such as Arduino IoT Cloud. All the mentioned features make this development board the preferred choice for emerging IoT projects [10].

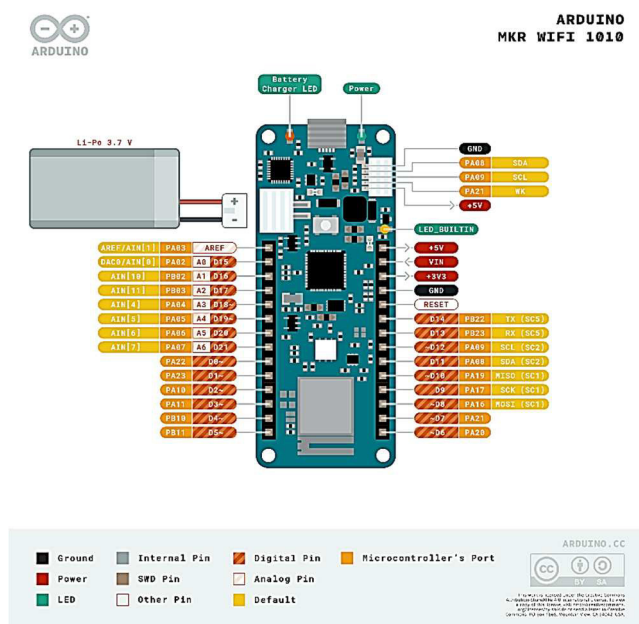

Fig. 7. Arduino MKR 1010 [11]

For more demanding requirements for performance or safety, Arduino also offers the PRO version, which is available under the name Portenta family – Portenta H7 (Fig. 8). However, the MKR 1010 board was also suitable for our purposes and requirements [12].

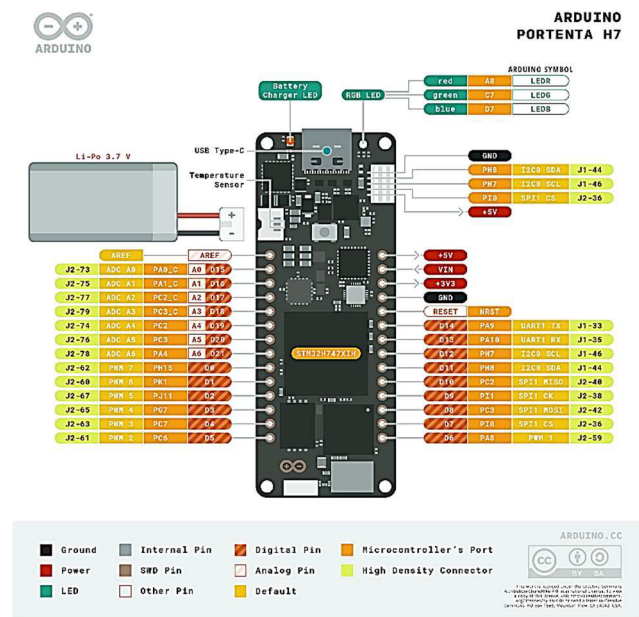

Fig. 8. Arduino Portenta H7 [12]

If it is not possible to use Wi-Fi communication in the practical application of the created system, it is necessary to choose a board containing a GSM module – specifically MKR GSM 1400 (Fig. 9). All inputs and outputs are identical to the Wi-Fi version of MKR 1010, so the resulting solution is easily modifiable in the GSM version [13; 14].

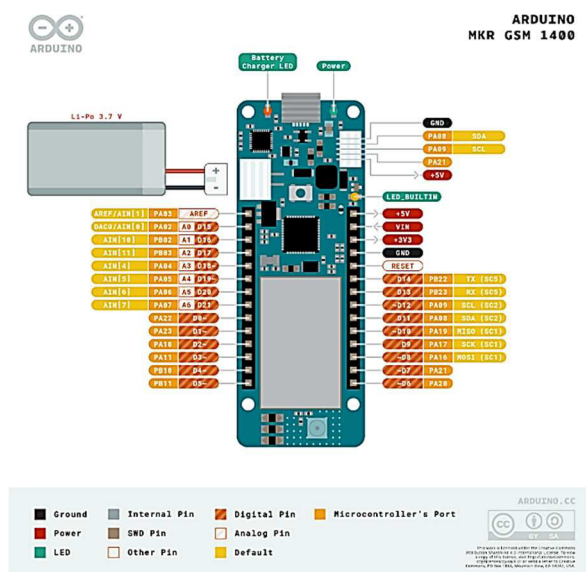

Fig. 9. Arduino MKR GSM 1400 [13]

Measuring chain. Deformations that we want to measure with strain gauges are usually very small. Changes in resistance are also minimal. It is not possible to measure them directly, so it is necessary to use an amplification module [1].

The resulting measuring chain (Fig. 10) consists of a strain gauges (beam on which strain gauges are applied). This module was used to simplify the preparation and testing of the solution. In practical use, strain gauges are applied to the monitored structure (depending on the stress we would like to monitor). Another element used is the HX711 amplifier conversion module. The connection between the strain gauges and the HX711 module is made using an electric "Wheatstone" voltage bridge. The HX711 module is used to amplify and convert the output signal to the Arduino MKR 1010 microcontroller, which displays the acquired data on the LCD display to the user and simultaneously sends the measured data to the cloud.

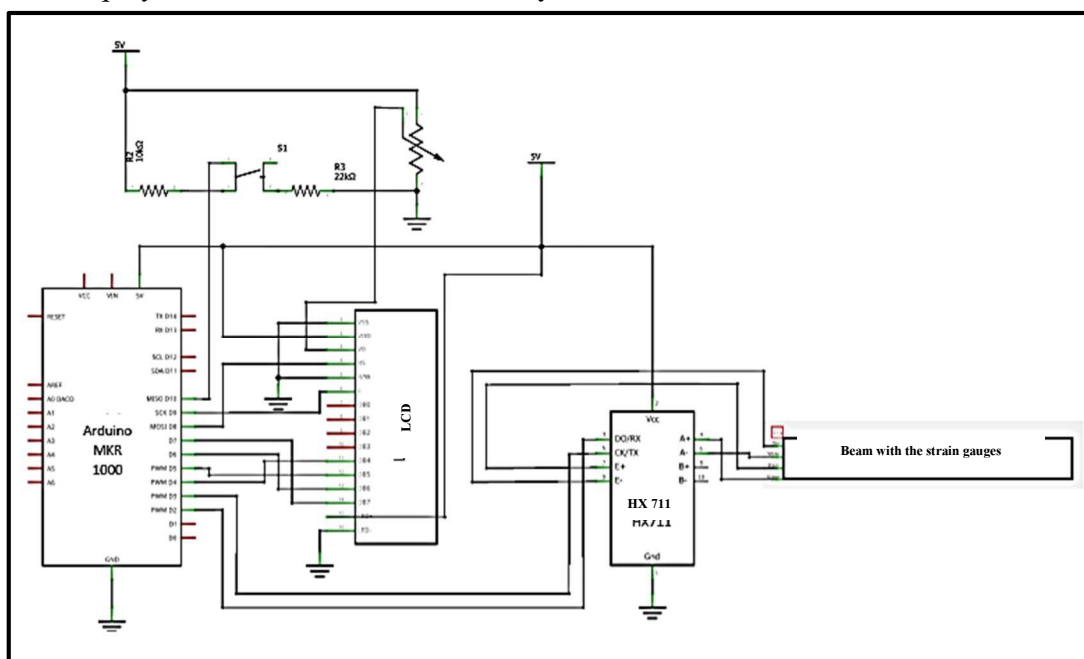

Fig. 10. Final measuring chain [16]

The final form of the monitoring equipment connection design developed in the Fritzing program is shown in (Fig. 11).

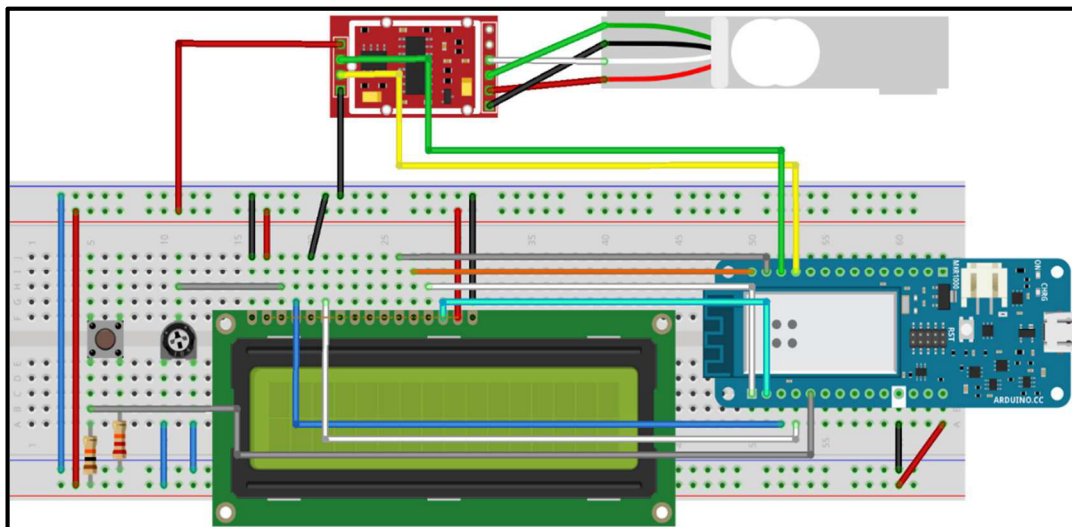

Fig. 11. Equipment connection design from Fritzing [16]

The software part of the solution was implemented on the Arduino IoT Cloud platform (Fig. 12). Arduino IoT Cloud is an Internet platform, containing a number of tools for connecting objects, devices within the Internet of Things and thus the rapid exchange of data in real-time. Ability to watch them from anywhere through a simple user interface [15].

```

1 //-----Nastavenia-----
2 // Bounce2 - Version: Latest
3 #include <Bounce2.h>
4 // LiquidCrystal - Version: Latest
5 #include <LiquidCrystal.h>
6 // HX711 Arduino Library - Version: Latest
7 #include <HX711.h>
8 #include "thingProperties.h"
9 #define BUTTON_PIN 10
10 const int LOADCELL_DOUT_PIN = 2;
11 const int LOADCELL_SCK_PIN = 3;
12 const int pin_RS = 8;
13 const int pin_EN = 9;
14 const int pin_d4 = 4;
15 const int pin_d5 = 5;
16 const int pin_d6 = 6;
17 const int pin_d7 = 7;
18 const int pin_BL = 10;
19
20 LiquidCrystal lcd( pin_RS, pin_EN, pin_d4, pin_d5, pin_d6, pin_d7);
21 HX711 scale;
22 Bounce debouncer = Bounce();
23 //-----Nastavenia-----
24
25
26 void setup() {
27 //Tato funkcia sa spusti len raz na zaciaku
28 //-----Inicializacia-----
29 debouncer.attach(BUTTON_PIN, INPUT); //nastavenie tlacidla
30 debouncer.interval(10); //nastavenie debouce intervalu
31 lcd.begin(16, 2); //inicializacia LCD displeja
32 lcd.setCursor(0, 0); //nastavenie kurzoru na LCD displeji
33 lcd.print("Starting..."); //vypis na LCD displeji
34 // Defined in thingProperties.h
35 initProperties(); //inicializacia Wi-fi a cloud nastaveni
36 // Connect to Arduino IoT Cloud
37 ArduinoCloud.begin(ArduinoIoTPreferredConnection); //Prinimanie na arduino cloud

```

Fig. 12. Sample of final code from Arduino IoT Cloud [16]

After creating the software, the functionality of the device was tested. An example of testing is shown in Fig. 13. Testing verified the functionality of the solution.

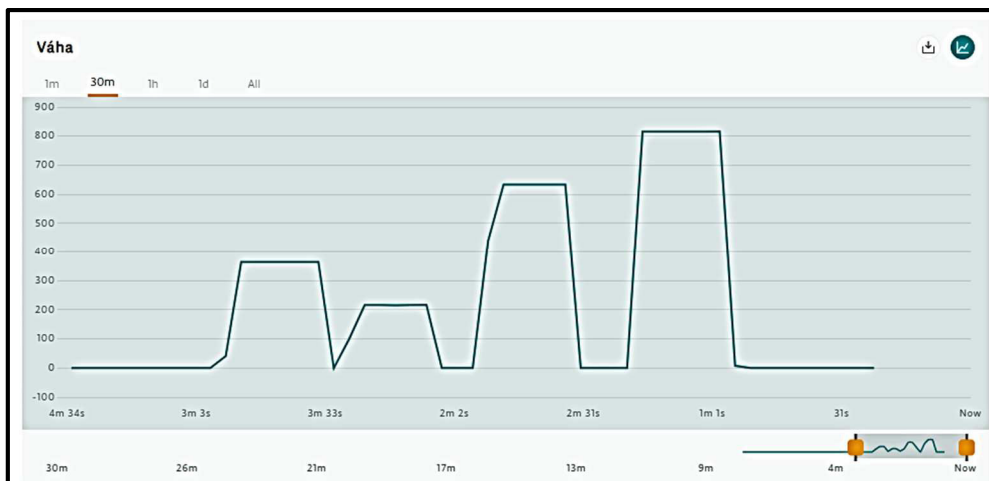

Fig. 13. Sample of testing [16]

Conclusions. This article aimed to present the possibilities of remote stress monitoring in structures using IoT technology. In the first part, we presented the existing commercially available options. These devices represent complex top monitoring possibilities, not only stress measurement - but they are financially demanding. That is why we decided to create a monitoring device, which is not so expensive. The advantage of the created device is also that it is possible to adjust it according to preferences. For example, if a Wi-Fi network is not available, the system can be modified to use the GSM network. It is also possible to modify the power supply - the device can be powered from the mains, or use a battery or solar cell as a source [16].

The created device is still in development, and it is necessary to work on its software page. The plan is to create a mobile application that would also include notification options that would alert the user to the achievement of critical values.

Acknowledgement. This work was supported by grant project VEGA 1/0330/19.

References

1. Trebuňa, F., Šimčák, F.: P. (2011), *Metódy experimentálnej analýzy napätosti*, TU v Košiciach, ISBN:978-80-553-0766-4 [in Slovak].
2. Serpanos, D., Wolf, M. (2018), *Internet-of-Things (IoT) Systems*, Springer International Publishing AG, ISBN:9783319697147 [in English].
3. A study of strain and deformation measurement using the Arduino microcontroller and strain gauges devices (2018), SciELO, Retrieved from https://www.scielo.br/scielo.php?script=sci_arttext&pid=S1806-11172019000300401 [in English].
4. HBM (2020), *QuantumX Data Acquisition System*, Retrieved from <https://www.hbm.com/en/2128/quantumx-compact-universal-data-acquisition-system/> [in English].
5. HBM (2020), *PMX Multi Channel Data Acquisition System*, Retrieved from <https://www.hbm.com/en/2981/pmx-modular-measuring-amplifier-system-for-the-iot/> [in English].
6. Embedded Micro Technology (2020), *MyPi*, Retrieved from <http://www.embeddedpi.com/integrator-board> [in English].
7. Industrial Shields (2020), <https://www.industrialshields.com/industrial-programmable-logic-controllers-based-on-arduino-raspberry-pi-and-esp32> [in English].
8. Arduino (2020), <https://arduino.cc> [in English].
9. Arduino MKR 1000 family (2020), Retrieved from <https://www.arduino.cc/pro/hardware/product-family/mkr-family?id=1996559>, [in English].
10. Javed, A. (2016), *Building Arduino Projects for the Internet of Things - Experiments with Real-World Applications*, Apress, ISBN-13: 978-1484219393 [in English].
11. Arduino MKR 1010 (2020), <https://store.arduino.cc/arduino-mkr-wifi-1010>, Retrieved from [in English].

12. Arduino Portenta H7 (2020), Retrieved from <https://www.arduino.cc/pro/hardware/product/portenta-h7> [in English].
13. Arduino MKR GSM 1400 (2020), Retrieved from <https://store.arduino.cc/arduino-mkr-gsm-1400-1415> [in English].
14. Rákay, R., Galajdová, A. (2019), Comparison of communication protocols for smart devices, Technical Sciences and Technologies, Chernihiv National University of Technology, v. 17, n. 3, p. 146-154, ISSN 2411-5363 [in English].
15. Arduino IoT Cloud (2020), Retrieved from <https://www.arduino.cc/en/IoT/HomePage> [in English].
16. Studený, M. (2020), Monitoring napätí v konštrukcii pomocou IoT, Košice [in Slovak].

УДК 620.17

Патрик Шарга, Мартін Студеній

МОЖЛИВОСТІ ВИМІРЮВАННЯ НАПРУЖЕНЬ У КОНСТРУКЦІЯХ ІЗ ВИКОРИСТАННЯМ СУЧАСНИХ ТЕХНОЛОГІЙ

Актуальність дослідження. У багатьох галузях промисловості важливим є визначення внутрішніх напружень різноманітних конструкцій. Ці данні необхідні для аналізу безпеки використання, постійного контролю за станом, планування технічного обслуговування, загального прогнозування терміну служби конструкцій, а також для інших цілей, спрямованих на економію фінансів та часу, що необхідні для ремонту.

Постановка проблеми. Метою дослідження є створення недорогого моніторингового пристрою за принципом IoT для контролю напружень у конструкції.

Аналіз останніх досліджень і публікацій. При розробці системи та підготовці даної статті враховані як точні джерела – публікації та статті, що стосуються сучасного стану розвитку моніторингових систем IoT, так і існуючі рішення, які доступні на ринку.

Виділення недосліджених частин загальної проблеми. На цьому етапі розглядається можливість створення мобільного додатку для визначення внутрішніх напружень у конструкціях. Його впровадження планується на наступному етапі розробки.

Мета дослідження. Метою статті є пояснення принципу створення системи моніторингу IoT за допомогою платформи Arduino.

Виклад основного матеріалу. У роботі використані компоненти торгової марки Arduino, яка є провідною апаратно-програмною екосистемою з відкритим кодом. Компанія пропонує широкий спектр програмних засобів, апаратних платформ та документації, що дозволяє майже будь-кому проявити творчий підхід до роботи з технологіями.

Висновки відповідно до статті. Створено пристрій моніторингу IoT на платформі Arduino. Програмна частина реалізована у середовищі Arduino IoT Cloud. Тестування пристрою підтвердило його функціональність під час практичного використання створеної системи. Передбачена можливість зміни пристрою для забезпечення його кращої відповідності зазначеним вимогам.

Ключові слова: Arduino; одноплатний комп'ютер (RPI) Інтернет речей (IoT); тензодатчики; Arduino IoT Cloud.
Рис.: 13. Бібл.: 16.

Patrik Šarga – Doctor of Technical Sciences, Associate Professor, Department of Automation and Human Machine Interactions, Faculty of Mechanical Engineering, Technical University of Košice (9 Letna Str., 041 00 Kosice, Slovakia).

E-mail: patrik.sarga@tuke.sk

ScopusAuthor ID: 15128102900

Martin Studený – student of mechanical engineering, Faculty of Mechanical Engineering, Technical University of Košice (9 Letna Str., 041 00 Kosice, Slovakia).

E-mail: martin.studený@student.tuke.sk